



*Need for Speed™ Underground*  
System Manual  
040-0049-01 Rev. A

- Read this manual before installing the Game.
- Keep this manual with the machine at all times.



www.globalvr.com  
<http://service.globalvr.com>  
[techsupport@globalvr.com](mailto:techsupport@globalvr.com)  
Phone: 408.597.3400  
Fax: 408.597.3431

© 2005 Electronic Arts Inc. Electronic Arts, Need for Speed, EA GAMES and the EA GAMES logo are trademarks or registered trademarks of Electronic Arts Inc. in the U.S. and/or other countries. All rights reserved. EA GAMES™ is an Electronic Arts™ brand. Dodge is a trademark of DaimlerChrysler Corporation. Dodge Neon and its trade dress are used under license by Electronic Arts Inc. ©:DaimlerChrysler Corporation 2004. Honda®, the 'H' logo®, Acura®, the stylized 'A' logo®, Civic®, Si™, Integra Type-R®, S2000™, RSX®, Type-R™ and Type-S™ names, emblems and body design elements are trademarks and/or intellectual property rights of Honda Motor Co., Ltd., used under license. Tiburon (Tuscani) is a registered trademark owned and licensed by Hyundai Motor Company. Mazda MX-5 Miata and Mazda RX-7 are used under the approval of Mazda Motor Corporation. Mitsubishi, Eclipse, and Lancer names, emblems and body designs are trademarks and/or intellectual property rights of Mitsubishi Motors Corporation and used under license to Electronic Arts Inc. NISSAN, SKYLINE, 350Z, SENTRA and 240SX are trademarks and/or intellectual property rights of NISSAN MOTOR CO.,LTD. And are used under license to Electronic Arts Inc. PEUGEOT 206 GTI S16 2003 is used under license from AUTOMOBILES PEUGEOT by Electronic Arts. SUBARU, IMPREZA and WRX names, emblems and body designs are properties of Fuji Heavy Industries Ltd. Toyota, Supra, and Celica are trademarks of Toyota Motor Corporation, and used with permission. Trademarks, design patents and copyrights are used with the permission of the owner VOLKSWAGEN AG. The names and logos of all after market car part companies are trademarks of their respective owners and are used by permission. All rights reserved. EA GAMES™ is an Electronic Arts brand. Global VR and the Global VR logo are registered trademarks of Global VR, Inc. All other trademarks are the property of their respective owners. U.S. Patent Nos. 5,269,687; 5,354,202; and 5,577,913 used under license from Midway Games West Inc

Tournaments are not sponsored or administered by Electronic Arts or their Licensors.

GLOBAL VR IS AN AUTHORIZED ELECTRONIC ARTS DISTRIBUTOR.

## Table of Contents

---

Preface.....	4	Registration Options.....	36
Safety.....	4	Chapter 6 — System Recovery and Game	
Warnings.....	5	Install CDs.....	37
Environmental Conditions.....	5	Using the System Recovery CD.....	37
FCC Notices (United States).....	5	Using the Game Install CDs.....	37
Chapter 1 — Introduction.....	6	Chapter 7 — Service and Repair.....	38
<i>Need for Speed</i> <sup>™</sup> Underground Description.....	6	Opening the Control Panel.....	38
<i>Need for Speed</i> <sup>™</sup> Underground Upgrade.....	6	Force-Feedback Steering System Service.....	39
Cabinet Specifications.....	7	5 K $\Omega$ Steering Pot (Potentiometer)	
Power Requirements.....	7	Replacement.....	40
Hardware Features.....	7	Force-Feedback Belt or Motor Replacement.....	40
Chapter 2 — Installing a New Cabinet.....	8	Force-Feedback PCB Replacement.....	41
Driving Seat Installation.....	9	Driving Control Panel Button Service.....	41
Marquee Setup.....	10	Pedal Assembly Service.....	42
Linking Cabinets.....	10	5 K $\Omega$ Gas and Brake Pot (Potentiometer)	
Linking Cabinets Without Broadband.....	11	Replacement.....	42
Linking Cabinets that use a Broadband		Six-Speed Shifter and E-Brake Service.....	43
Internet Connection.....	12	Six-Speed Shifter Replacement.....	43
Checking the Game Dongle.....	13	Six-Speed Shifter Micro Switch Service.....	43
Connecting an External Monitor.....	13	Shifter Bottom Plate Replacement.....	44
Chapter 3 — Playing a Game.....	14	E-Brake Button Service.....	44
Starting the Game.....	14	Driving Seat Slide Assembly Replacement.....	44
Game Play.....	15	Wells-Gardner <sup>®</sup> Monitor Replacement.....	45
Modes of Play.....	16	Wells-Gardner <sup>®</sup> Monitor Chassis PCB	
Operator-Run Local Tournaments.....	16	Removal.....	47
Chapter 4 — Setting Up Tournament Play.....	17	Audio Amp and Speakers Service.....	49
Getting Started.....	17	Audio Amp PCB Replacement.....	49
Cabinet Registration.....	17	Front (Marquee) Speaker Replacement.....	50
Navigating the Registration Screens.....	18	Center Speaker Replacement.....	50
Web Registration for Existing Operators.....	18	Rear (Seat) Speaker or Subwoofer	
Registration for Existing Operators without		Replacement.....	50
Web Access.....	18	Computer Replacement.....	50
Registration for New Operators.....	18	Coin Mech Replacement.....	52
Register With Your 4-Digit Registration Key.....	19	Coin Meter Replacement.....	52
Register with an Active Operator Card.....	22	Dollar Bill Validator Replacement.....	52
Chapter 5 — Operator Menu and Game		SmartCard Reader Replacement.....	53
Setup.....	26	SmartCard Dispenser Service.....	53
Navigating Through the Game Operator Menu		SmartCard Dispenser Replacement.....	53
Screens.....	26	Power Distribution Service.....	54
Machine Information Menu.....	28	AC Power Plate.....	54
Game and Coin Options Menu.....	29	AC Power Strip Replacement.....	55
Reset Stats/Settings Screen and Default		DC Power Supplies (+24 and +5/+12 VDC).....	55
Settings.....	30	Cabinet Lighting Service.....	56
Collection Statistics Screen.....	31	Marquee Florescent Light Service.....	56
Game Statistics Screens.....	31	Leader Light Service.....	57
Play Control Test.....	32	Brake Light Replacement.....	57
Monitor Calibration Test.....	33	Cold-Cathode Light Service.....	58
Sound Test.....	34	Setting the Computer BIOS (CMOS).....	59
System Test.....	35	Chapter 8 — Troubleshooting.....	61

Video Troubleshooting.....	61	Control Panel.....	69
Audio Troubleshooting .....	62	Cabinet and Marquee .....	70
Control Troubleshooting .....	62	Computer .....	70
Cabinet Linking Troubleshooting .....	64	Steering and Audio PCB Assembly .....	71
Miscellaneous Troubleshooting .....	65	Seat Assembly .....	71
Connection Troubleshooting.....	66	Artwork and Formed Plastic Components .....	73
External Monitor Troubleshooting .....	66	Chapter 10 — Diagrams and Schematics.....	74
Chapter 9 — Replacement Parts.....	69	Warranty Information .....	79
Documents and Software .....	69		
Cables .....	69		

## List of Figures

---

Figure 1. Need for Speed™ <b>Underground</b> Cabinet Dimensions.....	7	Figure 34. Cable Connections to the Monitor Chassis.....	45
Figure 2. Coin Door with Key Location.....	8	Figure 35. Monitor Mounting Nut Locations .....	46
Figure 3. Installing the Seat Runners.....	9	Figure 36. Removing the Monitor PCB Mounting Hardware.....	47
Figure 4. Attaching the Driving Seat to the Runners .....	10	Figure 37. Disconnecting the Chassis Neck PCB and Second Anode Lead .....	48
Figure 5. Setting up the Marquee.....	10	Figure 38. Monitor PCB Cables.....	48
Figure 6. Linking Cabinets Without Broadband.....	11	Figure 39. Audio Amp Connections, Volume Adjustment, and Speaker Location .....	49
Figure 7. Checking Link Status.....	11	Figure 40. Computer Mounting .....	51
Figure 8. Linking Cabinets with Broadband .....	12	Figure 41. Servicing the Coin Mech and Coin Meter .....	52
Figure 9. Parallel and USB Game Dongles .....	13	Figure 42. Dollar Bill Validator DIP Switch Settings.....	53
Figure 10. Selecting Track and Car Options.....	14	Figure 43. Filling the SmartCard Dispenser .....	54
Figure 11. Driving Screen Functions.....	15	Figure 44. AC Power Plate (Standard Cabinet).....	54
Figure 12. Registration Process Flowchart.....	17	Figure 45. DC Power Supply Connections.....	56
Figure 13. Setting Cabinet Volume .....	26	Figure 46. Cabinet Lighting Locations .....	56
Figure 14. Game Operator Menu Flowchart .....	27	Figure 47. Cold Cathode Florescent Light Wiring.....	58
Figure 15. Machine Information Screen.....	28	Figure 48. Selecting the Settings Tab in the Display Control Panel.....	67
Figure 16. Game and Coin Options Screen .....	29	Figure 49. Selecting the Video Card Name Tab .....	67
Figure 17. Reset Stats/Settings Menu .....	30	Figure 50. Choosing a Display Pair with Cloning.....	67
Figure 18. Collection Statistics Menu.....	31	Figure 51. Confirming Display Settings .....	68
Figure 19. Game Stats Menu Screens.....	31	Figure 52. Six-Speed Shifter Exploded View and Parts .....	72
Figure 20. Play Control Test Screen .....	32	Figure 53. Pedal Assembly Exploded View and Parts .....	72
Figure 21. Monitor Calibration Test Screen .....	33	Figure 54. Artwork and Formed Plastic Part Numbers and Locations .....	73
Figure 22. Monitor Remote Control Board .....	33	Figure 55. Audio Wiring .....	74
Figure 23. Sound Test Screen.....	34	Figure 56. Simplified Wiring Diagram .....	75
Figure 24. System Test Screen .....	35	Figure 57. Detailed Wiring Diagram .....	76
Figure 25. Registration Options Screen .....	36	Figure 58. Power Distribution Diagram .....	77
Figure 26. Opening the Control Panel .....	38	Figure 59. Computer Rear Panel Diagram .....	78
Figure 27. Force-Feedback Steering System Harnessing Diagram .....	39		
Figure 28. Replacing the 5 KΩ Steering Pot .....	40		
Figure 29. Servicing the Force-Feedback Motor.....	41		
Figure 30. Replacing Button Lamps .....	42		
Figure 31. Pedal Assembly Details .....	42		
Figure 32. Shifter Pattern and Micro Switch Actuation.....	43		
Figure 33. Seat Slide Assembly Replacement.....	45		

## Preface

---

### Safety

---

*Please read this page before preparing your arcade cabinet for game play.*

---

The following safety instructions apply to all game operators and service personnel. Specific warnings and cautions will be included throughout this manual.



Use the following safety guidelines to help protect the system from potential damage and to ensure your personal safety:

- Make sure that the switch on the back of the computer is set to match the AC power in use at your location:
  - 115 volts / 60Hz in most of North and South America and some Far Eastern countries such as Japan, South Korea and Taiwan
  - 230 volts / 50Hz in most of Europe, the Middle East and the Far East
- To help prevent electric shock, plug the system into a properly grounded power source. These cables are equipped with 3-prong plugs to help ensure proper grounding. Do not use adapter plugs or remove the grounding prong from a cable. If you must use an extension cable, use a 3-wire cable with properly grounded plugs.
- To help protect your system from sudden increases and decreases in electrical power, use a surge suppressor, line conditioner or Uninterruptible Power Supply (UPS).
- Be sure nothing rests on the system's cables and that the cables are not located where they can be stepped on or tripped over.
- Keep your system far away from radiators and other heat sources.
- Do not block cooling vents.

### Precautions for Game Operation

- To avoid injury and accidents, people who fall under the following categories should not play the game:
  - Those who need assistance when walking.
  - Those who have high blood pressure or a heart problem.
  - Those who have experienced muscle convulsions or loss of consciousness when playing a video game or similar activities.
  - Those who have trouble in the neck or spinal cord.
  - Intoxicated persons.
  - Pregnant women.
  - Persons susceptible to motion sickness.
  - Persons who do not abide by the warning labels on the game.
- A player who has never been adversely affected by light stimulus might experience dizziness or headache when playing the game. Small children can be especially susceptible to these conditions. Caution guardians of small children to keep watch over their children during play.
- Instruct those who feel sick during play to see a doctor.
- To avoid injury from falling objects, and electric shock due to spilled drinks, instruct players not to place heavy items, food, or drinks on the product.
- To avoid electric shock or short circuit, do not allow customers to put hands and fingers or extraneous matter in the openings of the product.
- To avoid risk of injury from falling, immediately stop customers from leaning against or climbing on the product.

## Warnings

 <b>CAUTION</b>	<p>To avoid electrical shock, unplug the cabinet before performing installation or service procedures.</p>
 <b>STOP</b>	<p>GLOBAL VR® assumes no liability for any damages or injuries incurred while setting up or servicing the cabinet. Only qualified service personnel should perform installation or service procedures!</p>

## Environmental Conditions

Cabinet is intended for indoor use only. Be sure to keep the cabinet dry and maintain operating temperatures of 10°-40°C (50°-104°F).

## FCC Notices (United States)

Electromagnetic Interference (EMI) is any signal or emission radiated in free space or conducted along power or signal leads, that endangers the functioning of radio navigation or other safety service, or that seriously degrades, obstructs, or repeatedly interrupts a licensed radio communications service. Radio communications services include, but are not limited to, AM/FM commercial broadcast, television, cellular services, radar, air-traffic control, pager, and Personal Communication Services (PCS). These licensed services, along with unintentional radiators such as digital devices (including computer systems) contribute to the electromagnetic environment.

Electromagnetic Compatibility (EMC) is the ability of items of electronic equipment to function properly together in the electronic environment. While this computer system has been designed and determined to be compliant with regulatory agency limits for EMI, there is no guarantee that interference will not occur in a particular installation. If this equipment does cause interference with radio communications services, which can be determined by turning the equipment off and on, you are encouraged to try to correct the interference by one or more of the following measures:

- Re-orient the receiving antenna.
- Relocate the cabinet relative to the receiver.
- Plug the game into a different outlet so that the computer and the receiver are on different branch circuits.

If necessary, consult a Regulatory EMC representative of GLOBAL VR® or an experienced radio/television technician for additional suggestions. You may find the [FCC Interference Handbook](#), to be helpful. It is available from the U.S. Government Print Office, Washington, DC 20402.

This device has been tested and complies with the limits for a Class A digital device pursuant to Part 15 of the FCC Rules. These limits are designed to provide reasonable protection against harmful interference when the equipment is operated in a commercial environment. This equipment generates, uses, and can radiate radio frequency energy. If not installed and used in accordance with the instruction manual, it may cause harmful interference with radio communications. Operation of this equipment in a residential area is likely to cause harmful interference, in which case you will be required to correct the interference at your own expense.

Operation is subject to the following conditions:

- This device may not cause harmful interference.
- This device must accept any interference received, including interference that may cause undesired operation.

## Chapter 1 — Introduction

---

### *Need for Speed™* Underground Description

Build and race the ultimate urban exotic with *Need for Speed™* **Underground**.

Take control of top import street tuners like Toyota Celica, Nissan 350Z, Mitsubishi Eclipse and the exclusive Nissan Skyline GT-R. Play Career and customize your car with licensed aftermarket parts to build your own unique ride.

Force-feedback steering, surround sound and a 6-speed shifter make *Need for Speed™* **Underground** a truly engaging driving experience.

### Own the Streets

- **Linkable** – allowing up to 4 players to compete in blistering head-to-head competition.
- **Tournament Play** – with National Tournaments and Wednesday Tournament events throughout the US.
- **Career Mode** – allows players to choose their car and compete in a series of 81 races, earning custom performance parts and upgrades along the way.
- **GLOBAL VR® Players' Card Compatible** – thousands of registered players are ready to drive, and new players can purchase a SmartCard format Players' Card to store their data.

### *Need for Speed™* Underground Upgrade

The *Need for Speed™* **Underground** Upgrade Kit is available for existing *Need for Speed™* cabinets. The upgrade kit includes the new *Need for Speed™* **Underground** software, 6-speed shifter, Players' Card reader (for Tournament and Career Mode play), NOS button, and new artwork.

## Cabinet Specifications

The standard cabinet is pictured below. A deluxe cabinet with a 39-inch monitor is also available by special order. Upgrade kits are available to convert existing *Need for Speed*<sup>™</sup> cabinets to run *Need for Speed*<sup>™</sup> **Underground**.



Figure 1. *Need for Speed*<sup>™</sup> **Underground** Cabinet Dimensions

## Power Requirements

Voltage	Inrush AC Current (Amps)	Operating AC Current (Amps)
115	6.5	4
220	3	2

## Hardware Features

- Pentium 4 Computer
- Nvidia GeForce Graphics Card
- Six-Channel Surround Sound
- 27-Inch, 800x600, Super VGA Flat-Screen Monitor
- Force-Feedback Steering
- Six-Speed Shifter
- SmartCard Reader
- SmartCard Dispenser

## Chapter 2 — Installing a New Cabinet

---

Use the following procedure to set up your game:

1. Carefully remove the cabinet from the shipping container, giving yourself plenty of space. Inspect the exterior of the cabinet for any damage.
2. Remove the keys from the coin return slot. Open the coin door to locate the second set of keys.

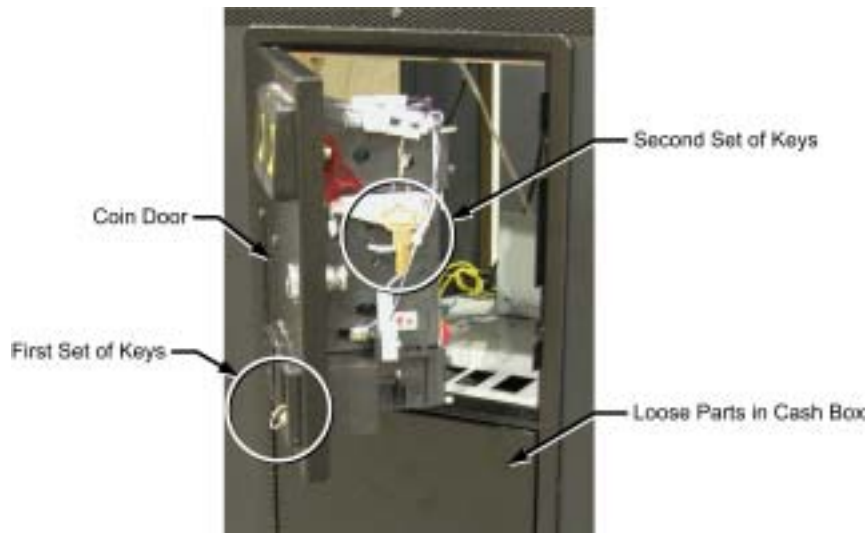

*Figure 2. Coin Door with Key Location*

3. Open the cash-box door and remove the loose parts inside the cash box. You will find the following items (may vary with cabinet style):
  - 10/100 Base-T Network Cable
  - 10/100 Base-T Crossover Coupler
  - Phone Cord
  - AC Power Cord
  - T-25 Torx Security Bit
  - Hardware for Attaching Driving Seat Assembly
  - System Manual (This Document)
  - Software Restore Guide
  - System Recovery Disk (1 CD)
  - Game Install Disks (2 CDs)
4. Remove the back door from the cabinet. Verify that all cables and wires are securely connected to the computer and other components. See Chapter 10 — Diagrams and Schematics for wiring and connection diagrams.
5. Connect the AC power cord from the cabinet to a grounded (3-terminal) AC wall outlet.
6. Power ON the cabinet using the ON/OFF switch located on the lower rear of the cabinet. Verify that the game boots properly.

- If the SmartCard reader is not connected, or the SmartCard dispenser is empty, a screen, shown below, will appear. These screens will time out after 30 seconds, or you can press the **START** and **NOS** buttons to continue.

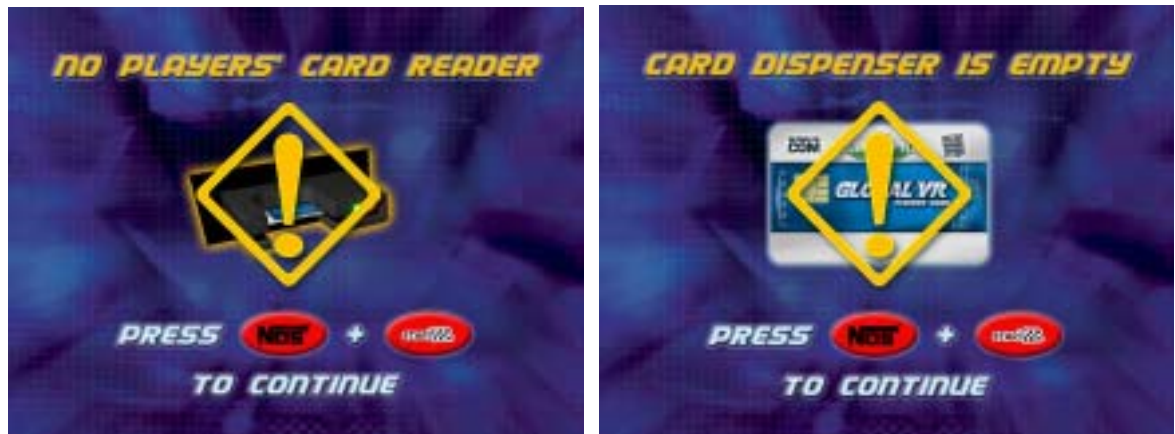

- Once the Attract movie starts, play a game to verify that everything works properly.
- Turn the cabinet OFF and disconnect the power cord before installing the seat assembly.

## Driving Seat Installation

- Look in the cash box to locate the hardware used to attach the driving seat.
- The seat runners may be packaged and placed with the seat or cabinet, or installed backwards in the cabinet. If the seat runners are installed backwards for shipping, use a 7/16" socket wrench to remove the four (4) 1/4-20 x 1-1/4" hex bolts with lock washers and flat washers that hold each seat runner inside the cabinet. See item A in Figure 3 below.
- Insert the seat runners so that they extend out from the cabinet, as shown below. Secure them with the four (4) 1/4-20 x 1-1/4" hex bolts with lock washers and flat washers.

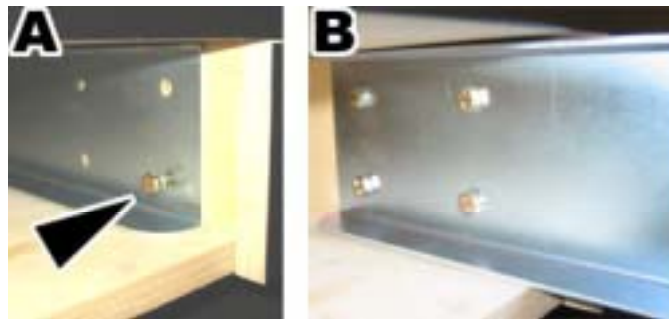

*Figure 3. Installing the Seat Runners*

- Slide the driving seat onto the seat runners, leaving enough space to connect the harnesses.
- Locate the two wire harnesses inside the driving seat, and inside the cabinet, near where the seat runners are installed. Connect the harnesses together as shown in item A of Figure 4. The connectors are keyed to prevent incorrect wiring.

- Slide the driving seat towards the cabinet while guiding the wire harnesses inside. Attach each driving seat to the seat runners using four (4) 2-1/4" T-27 Torx screws with 1/4" lock washers and fender washers. See item B of Figure 4.

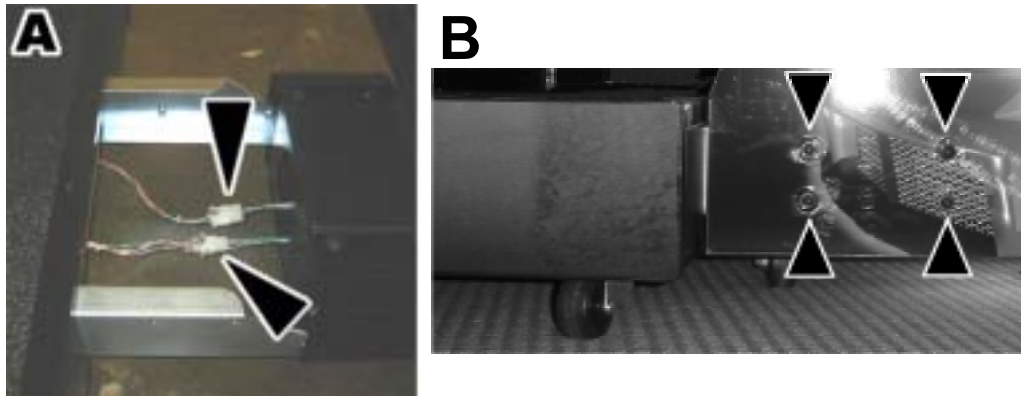

Figure 4. Attaching the Driving Seat to the Runners

## Marquee Setup

- Rotate the marquee forward towards the front of the cabinet as shown in the figure below.
- Install three (3) 1/4-20 x 1-1/2" T-27 Torx bolts through the holes in the metal bracket at the edge of the marquee support brace into the T-nuts in the top of the cabinet to secure the support brace.



**Warning: Until the bolts are in place, the marquee can slide back and could cause injury.**



Figure 5. Setting up the Marquee

The cabinet is now ready for game play.

## Linking Cabinets

You can link up to four cabinets together for head-to-head competition. Once the cabinets are linked in hardware and software, the Attract Mode movies will synchronize, and players can choose to play individually, or race against other players.

Each cabinet ships with an Ethernet cable and a cross-over coupler. The cross-over coupler is used to link two cabinets. An Ethernet hub is required to link more than two cabinets. If you use broadband instead of dial-up for connecting the cabinets to the Internet to sync with

GLOBAL VR<sup>®</sup>, you must use a router to link your cabinets. The table below shows required equipment by type of Internet connection and number of cabinets.

Number of Cabinets	Internet Connection	Linking Equipment Required
2	Dial-up or None	Cross-over coupler (Included with cabinet)
3 or 4	Dial-up or None	Ethernet hub (10/100 Mbps)
2, 3, or 4	Broadband	Ethernet router (Netgear <sup>®</sup> RP614v2 router recommended)

### Linking Cabinets Without Broadband



Figure 6. Linking Cabinets Without Broadband

1. **Before connecting the Ethernet cables**, go into the Operator Menu on each cabinet, and set the Cabinet Link ID number, as shown by the arrow in Figure 7. Each cabinet must have a unique number: 1, 2, 3, or 4. Cabinets should be numbered from left to right. Exit the Operator Menu to reset the number in the software.
2. Locate the 10' Ethernet cable and Ethernet crossover coupler in the cash box of each cabinet.
3. Connect the Ethernet cable to the Ethernet connector on the power plate of each cabinet.
  - **To link two cabinets:** Connect the two Ethernet cables to one cross-over coupler. **Do not** use two couplers.
  - **To link three or four cabinets:** Connect the Ethernet cables to an Ethernet hub or switch (not included). Connect the hub or switch to AC power and make sure it is powered ON. **Do not** use cross-over couplers with a hub or switch.
4. If more than one cabinet has the same Cabinet Link ID number, each cabinet with a duplicate ID number will display an error message, as shown below. Repeat Step 1 to correct the duplicate Cabinet Link ID numbers.



Figure 7. Checking Link Status

## Linking Cabinets that use a Broadband Internet Connection

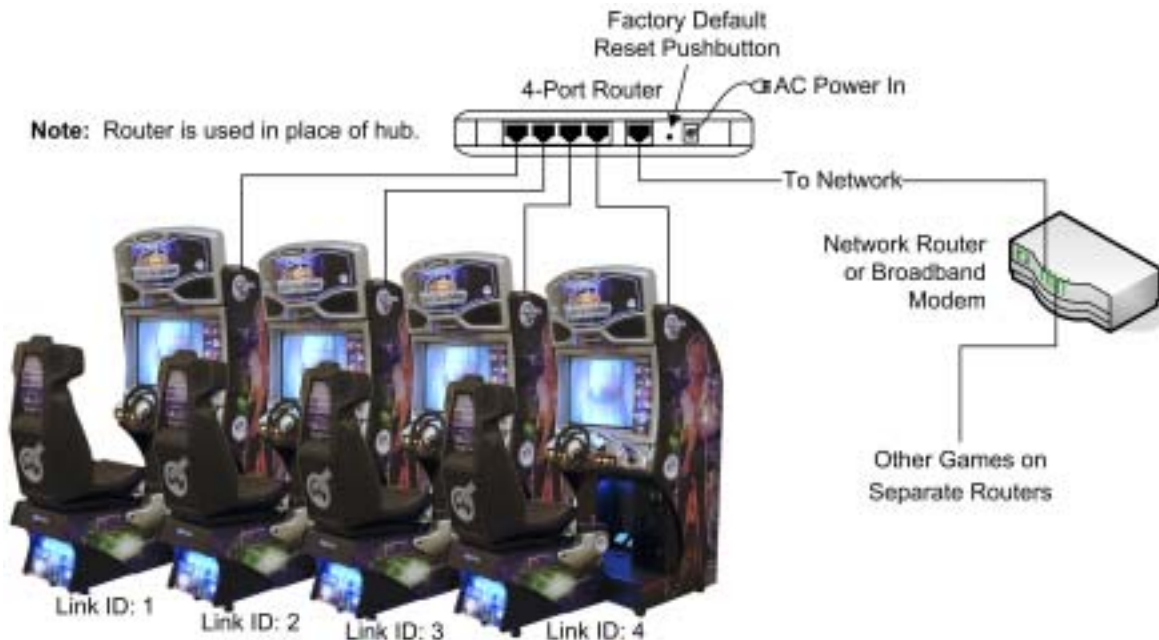

Figure 8. Linking Cabinets with Broadband

This procedure was tested using a Netgear® RP614v2 router. GLOBAL VR® does not offer support for other router brands or models.

**Important:** Your *Need for Speed™ Underground* cabinets must be connected to a separate router from any other games or devices.

1. **Before connecting the Ethernet cables**, go into the Operator Menu on each cabinet, and set the Cabinet Link ID number, as shown by the arrow in Figure 7. Each cabinet must have a unique number: 1, 2, 3, or 4. Cabinets should be numbered from left to right. Exit the Operator Menu to reset the number in the software.
2. Connect your Cable/DSL router to AC power.
3. The router must be configured to Factory Default Settings. If you have used the Router before, or changed its settings, press and hold the reset button until the Test LED turns on (about 10 seconds).
2. Connect the **Internet** port of the router to your network. (**Note:** The router takes the place of the hub for broadband.)
4. Connect an Ethernet cable to the Ethernet connector on the power plate of each cabinet, and to router ports **1—4** as shown in Figure 8. **Do not** use crossover couplers.
5. If more than one cabinet has the same Cabinet Link ID number, each cabinet with a duplicate ID number will display an error message, as shown in Figure 7. Repeat Step 1 to correct the duplicate Cabinet Link ID numbers.
6. Attempt to force a call from the System Test screen of the Game Operator menu of each cabinet, to verify that the connection is working properly.

If the cabinets are able to sync with GLOBAL VR®, you have successfully set up your connections. If a cabinet cannot sync, an error message will be displayed.

## Checking the Game Dongle

The cabinet uses a game dongle to activate the game software. Depending on the type of dongle shipped with the game, it connects to either the parallel port or the USB port on the back of the computer. If the dongle is missing, the game will not run.

When a USB Dongle is installed and working properly, a **red** LED will illuminate inside the dongle. A Parallel Dongle does not light up.

For a Game Dongle to be recognized correctly, it should be connected before the cabinet is powered ON. If the software does not recognize the Game Dongle, make sure the Dongle is connected properly, and then power cycle the cabinet to see if this resolves the problem.

If the dongle should come out while the game is running, a NO DONGLE screen will appear. If this happens, the dongle can be re-installed without rebooting the game.

**Note:** The dongle supplied with the cabinet is specific to the game and software version. Future software upgrades may require you to also upgrade the dongle.

**Important:** Some of your registration information is stored in the dongle, so if you replace your computer, **remove the dongle and keep it with the cabinet.**



*Figure 9. Parallel and USB Game Dongles*

## Connecting an External Monitor

If you wish, you can use the S-video connector on the computer video card to connect an external TV monitor and display the game action outside of the cabinet.

**Important:** If you install the operating system with the System Restore Disk while a second monitor is connected, an NVIDIA dialog box will appear onscreen after the large GLOBAL VR<sup>®</sup> logo appears at the end of the installation process. When you see this screen, power-cycle the cabinet and then proceed with the game software installation.

If your cabinet has an FX 5700 video card, you cannot use the S-video and VGA ports at the same time. In this case, you must purchase a DVI-to-VGA adapter and use this adapter to connect the cabinet monitor to the DVI port.

**Important:** Turn the cabinet OFF before making any video connections.

In most cases, the external monitor should not require any special setup. In some cases the Attract Movie may not show up on the screen. If this happens, refer to External Monitor Troubleshooting on page 79.

## Chapter 3 — Playing a Game

### Starting the Game

With the proper number of coins inserted, press the red **Start** button to begin the game. First select your mode of play, Race, Career, or Tournament (see page 79). Next a series of screens will appear, as shown below, allowing you to select options for the game.



Figure 10. Selecting Track and Car Options

1. **Track Select:** Turn the steering wheel to highlight each track displayed at the top of the screen. The track map and difficulty (*Easy*, *Medium*, or *Hard*) are displayed as you highlight each track. Press the gas pedal to select a track.
2. **Car Select:** Turn the steering wheel to highlight each car displayed at the top of the screen, and press the gas pedal to select your car.
3. **Customize:** Turn the steering wheel to highlight each customization shown at the top of the screen. Your car is displayed in each highlighted color. Press the gas pedal to make a selection.
4. **Transmission:** Select either automatic or manual transmission. Manual transmission (using the 6-speed shifter) may result in better speed control and faster race times for experienced drivers. No clutch is used, only the shifter.
5. **Other Options:** At any time during the car, customization, or transmission selection screens, you can press a control panel button for other options. These options are set through pop-up menus that display for five seconds.
  - Press **NOS** to turn AI on or off. In a linked race, any player can turn AI off for all cabinets. Turning AI off removes computer-controlled cars from the track. For a driver racing solo, this also activates **Shadow Attack Mode**, in which the driver races against a shadow of the track leader.
  - Press **Look Back** to turn Handicap (catch-up) on or off (default is on) for one driver only. Handicap helps a driver catch up with other cars.
  - Press **♪** to toggle the Force-Feedback level through Light, Medium, or Heavy.

Once you have selected your options, the game will begin to load.

## Game Play

As in any driving game, use the Steering Wheel, Gas, Brake and Shifter to control the car.

The **Look Back** button lets you look behind the car. The **View** button toggles the view between inside and outside the car. Tap the 🎵 button to turn the music off; tap it again to change songs. Press the **NOS** button for an extra burst of speed—but quantities are limited! Tap the **E-Brake** button to start a drift.



*Figure 11. Driving Screen Functions*

During the race, useful information is displayed onscreen:

1. Shows the number of the lap you are currently driving, and the total laps to complete the race.
2. Shows your current time for the lap and the best recorded lap time.
3. Shows your position (green triangle) relative to the other cars (red triangles) on a track map.
4. Shows your car's turbo level.
5. Shows the number of seconds you have to cross the next checkpoint. A Shadow Attack icon is displayed above this number if you are in Shadow Attack mode.
6. Shows your position in the race out of the total number of cars.
7. Shows the time gap between you and the leader, or the car behind you if you are in the lead.
8. Shows style points earned for advanced driving techniques.
9. Tachometer, shows your engine RPM in thousands.
10. Shows your current gear. In manual, the gear position in the shift pattern is also displayed.
11. Shows your speed in either KPH or MPH (set in Game Operator menu).

Additional information will appear onscreen depending on the race mode and options selected. At the end of the race, the time and position for each driver is displayed.

## Modes of Play

**Race Mode (amusement):** This is normal racing, requiring no Players' Card or online services. If cabinets are linked, players can race against each other head-to-head.

Using a Players' Card in Race Mode makes another car available for the player to drive. Also, a player can track miles on a Players' Card, and after 300 miles, another car becomes available.

**Career Mode:** In this mode, players drive a series of races. For each race they finish within a specified time, they win a customization or performance upgrade for their car. Players save their car and points on their Players' SmartCards. Players who complete a career (81 different races) can re-race any Career Mode race. Players can also use their customized Career Mode car in Race Mode.

**Tournament Mode:** If a cabinet is registered and online, players can compete in tournaments to win cash and prizes. To participate, players need a Players' SmartCard. Check the GLOBAL VR<sup>®</sup> website ([www.globalvr.com](http://www.globalvr.com)) for the latest Tournament information.

## Operator-Run Local Tournaments

If a cabinet is registered and online, operators can create their own Local Tournaments through the GLOBAL VR<sup>®</sup> website ([www.globalvr.com](http://www.globalvr.com)). Operators can set up a local tournament on one cabinet, or on a number of cabinets at any of their locations. They can list the tournaments on the GLOBAL VR<sup>®</sup> website to attract players.

**Note:** Certain regions have local restrictions on tournament play.

## Chapter 4 — Setting Up Tournament Play

### Go Online With GLOBAL VR® and Get More From Your Equipment Investment

**More Players** – Top players find your games through our online Game Locator.

**More Free Time** – Online equipment management lets you adjust and account without leaving your desk.

**More Play Modes** – Players at all levels have more ways to enjoy their favorite games.

**More Cash** – Increased earnings with Tournament Play and other online-only features.

### Getting Started

Register with the GLOBAL VR® Tournament System to connect your game cabinets to our online servers. Being online opens Tournament Play and other new play modes for your players and time-saving services for you. Getting started is easy:

1. If you do not have an account with GLOBAL VR®, fax in the Operator Agreement form located in the Registration Pack of the Welcome Kit included with your cabinet or upgrade kit.
2. Connect your cabinet to a phone line or broadband network. (See page 79 for important information about using broadband with linked cabinets.)
3. Register your cabinet as described below.

### Cabinet Registration

You have four options for registering your cabinet:

- **New Operators:** Go to page 79.
- **Existing Operators:**
  - Register through our website: Go to page 79.
  - Obtain a 4-digit registration key if you do not have web access: Go to page 79.
  - Register with your Active **Operator Plus™ SmartCard**: Go to page 79.

**Note:** For existing operators setting up a cabinet in a new location, it is probably easiest to register through the website.

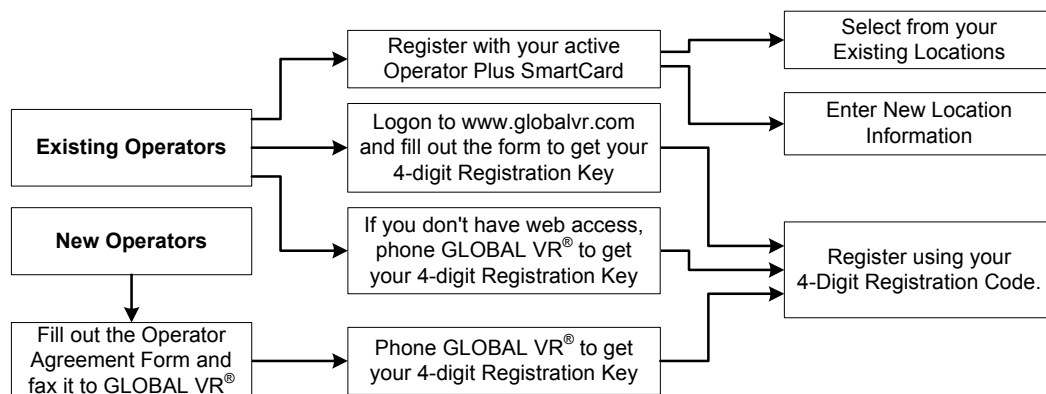







Figure 12. Registration Process Flowchart

## Navigating the Registration Screens

Use the driving control panel buttons to navigate the registration screens, as shown below. Also look for onscreen instructions and hints near the bottom of each screen.

Button	Function	Button	Function
	Up		Back or Exit Left (In Some Screens)
	Down		Select Right (In Some Screens)
	Select (In Some Screens)	Steering Wheel	Right & Left (In Some Screens)

## Web Registration for Existing Operators

Perform the following steps to register online if you have an account with GLOBAL VR<sup>®</sup>.

**Note:** You will need to provide the cabinet serial number, found on a label on the back of the cabinet, for each cabinet you wish to register.

1. Go to the GLOBAL VR<sup>®</sup> website, [www.globalvr.com](http://www.globalvr.com).
2. Click the **Operator** tab and login using your Operator ID and password.
3. Click the **MY CABINETS** tab near the top of the page.
4. From the menu on the left side of the Cabinets screen, under **Racing**, select **Registration**.
5. Fill out the Registration Form. In the **Select Existing Location** field, you can select New Location, or one of your existing locations. When you finish the form, click the **Create** button.
6. A Cabinet Registration Confirmation screen will appear. Find your 4-digit **Registration Key** near the top of the page, and write it down. Use this number at the cabinet to complete the registration process and activate your Operator card. (The Registration Key expires after one week.)
7. Repeat the steps above for each cabinet that you wish to register.
8. Proceed to the section titled Register With Your 4-Digit Registration Key, on page 79.

## Registration for Existing Operators without Web Access

Perform the following steps if you have an account with GLOBAL VR<sup>®</sup> but no Web access.

**Note:** You will need to provide the cabinet serial number, found on a label on the back of the cabinet, for each cabinet you wish to register.

1. Phone GLOBAL VR<sup>®</sup> Tournament Support, at 408.597.3400, to receive a 4-digit cabinet registration key for each cabinet that you wish to register.
2. Proceed to the section titled Register With Your 4-Digit Registration Key, on page 79.

## Registration for New Operators

If you are a new operator and do not have a GLOBAL VR<sup>®</sup> Operator Account, perform the following steps to get your cabinet registered and online:

1. Fill out Operator Agreement form, located in the Registration Pack of the Welcome Kit included with your cabinet or upgrade kit. Fax the form to GLOBAL VR<sup>®</sup>, at 408.597.3439.

**Note:** When you phone Tournament Support, you will need to provide the cabinet serial number, found on a label on the back of the cabinet, for each cabinet you wish to register.

2. Phone GLOBAL VR<sup>®</sup> Tournament Support, at 408.597.3400, to complete the registration process and create your Operator Account. You will receive the following:
  - A 4-digit registration key for each cabinet you are registering. You will use the registration key at the cabinet to complete the registration process and activate your Operator card. (The 4-digit registration key expires after one week.)
  - An Operator ID and password. Use these in the future to logon to our website to get your 4-digit registration key for cabinet registration. Your ID also gives you access to the **Global Impact Operator's Online Store**.
3. Proceed to the section titled Register With Your 4-Digit Registration Key, that follows.

### Register With Your 4-Digit Registration Key

1. Press the Operator button inside the coin door and select **Registration Options** from the Game Operator Menu. The Registration screen will appear.
2. Press the **1** button to enter the Registration screen. Select **Cabinet Registration** and press the **1** button again to begin the registration process.



3. Read the Acknowledgement screen, select Agree, and then press the **1** button to continue. You must select **Agree** to continue with registration.
4. The Dial-up Phone settings screen will appear next. **Phone Option** is set to **Dial-up** as default.

To use a broadband connection, press **↵** with **Phone Option** selected, and then press **VIEW** and **LOOK BACK** to toggle between **Broadband** and **Dial-up**. Press **↵** to select. If using Broadband, skip to step 6.



5. To use a dial-up phone line, keep **Dial-up** as the Phone Option, and use the buttons to set the dial-up properties as described below:
  - a. Use **VIEW** and **LOOK BACK** to select **State** and press **↵**. Use **VIEW** and **LOOK BACK** to scroll through the list of states. Press **↵** to select your state from the list.
  - b. Use **VIEW** and **LOOK BACK** to select Primary City and press **↵**. Use **VIEW** and **LOOK BACK** to scroll through the list of cities. Press **↵** to select your city or the city closest to the cabinet location.
 

**Hint:** Press the gas pedal while scrolling the list of cities to jump to the next letter.
  - c. Use **VIEW** and **LOOK BACK** to select Primary Number and press **↵**. Use **VIEW** and **LOOK BACK** to scroll through the list of phone numbers for your city. Press **↵** to select a local phone number.
  - d. Select **Yes** for **Skip Area Code** unless the area code for the selected number is different from the line the cabinet will be using. (If the cabinet needs to dial an area code, you will also need to enter a “1” as a dialing prefix in the next step.)
  - e. If you need to dial a number (such as “9”) to call outside of your location, or if your modem will be dialing an area code and needs to dial a “1” first, select **Dialing Prefix** and press **↵**. This will select the onscreen keypad.
 

Use **VIEW**, **LOOK BACK**, **↵**, and **NOS**, to select each number from the onscreen keypad, and press **START** to enter it. Select the comma (,) to insert a pause in the dialing. To make a correction, select **DELETE** on the onscreen number pad and press **START**. When you are finished, select **ENTER** on the number pad and press **START**.
  - f. Repeat Steps b—e for the Secondary City. (If your Primary City has more than one dial-up number, select the same city and a different number.) The computer will use this dial-up number as a backup if it cannot reach the primary number.
  - g. When you finish, the Primary and Secondary numbers will be displayed onscreen, with the dialing prefix and area code, if entered. Check the entries, and use the buttons to return to any entry that you wish to change. When you are finished, Use **VIEW** and **LOOK BACK** to select **Continue**, and press **↵**.

6. The Time Zone screen will appear next. Use VIEW and LOOK BACK to select your time zone and press ↵.
7. The Select Registration Method screen will appear next. Select **Register with a 4-Digit Code** and press ↵.



8. On the Enter your 4-digit code screen, use **VIEW**, **LOOK BACK**, ↵, and **NOS**, and/or steering wheel, to select each number from the onscreen keypad, and press **START** to enter it. If you make a mistake, select **Delete** and press **START**.
9. When you are finished, select **Enter** and press **START**.

You will see "Connecting..." followed by "In progress..."

When the process finishes, you will see "Registration Successful." Your cabinet is now registered.

**Important:** If you never see the Registration Successful screen, this can indicate a problem with registration, possibly an interrupted modem connection. Select Force Call from the Registration Options screen to make sure that your cabinet is able to sync with GLOBAL VR®, and to finalize registration.

10. After registration, you will be prompted to insert your Operator card to activate it. When the **Card Activation Successful** screen appears, your SmartCard will be active and can be used to register other cabinets. You can skip this step if you do not wish to activate a card at this time. You can activate an Operator Card at any time from the Registration Options screen.

Your cabinet is now registered. It is a good idea to set the sync time on the Registration Options screen so that your cabinets call in to GLOBAL VR® at different times. Also make sure the cabinet will be powered on at the selected sync time.



- b. Use **VIEW** and **LOOK BACK** to select Primary City and press **↵**. Use **VIEW** and **LOOK BACK** to scroll through the list of cities. Press **↵** to select your city or the city closest to the cabinet location.

**Hint:** Press the gas pedal while scrolling the list of cities to jump to the next letter.

- c. Use **VIEW** and **LOOK BACK** to select Primary Number and press **↵**. Use **VIEW** and **LOOK BACK** to scroll through the list of phone numbers for your city. Press **↵** to select a local phone number.
- d. Select **Yes** for **Skip Area Code** unless the area code for the selected number is different from the line the cabinet will be using. (If the cabinet needs to dial an area code, you will also need to enter a “1” as a dialing prefix in the next step.)
- e. If you need to dial a number (such as “9”) to call outside of your location, or if your modem will be dialing an area code and needs to dial a “1” first, select **Dialing Prefix** and press **↵**. This will select the onscreen keypad.

Use **VIEW**, **LOOK BACK**, **↵**, and **NOS**, to select each number from the onscreen keypad, and press **START** to enter it. Select the comma (,) to insert a pause in the dialing. To make a correction, select **DELETE** on the onscreen number pad and press **START**. When you are finished, select **ENTER** on the number pad and press **START**.

- f. Repeat Steps b—e for the Secondary City. (If your Primary City has more than one dial-up number, select the same city and a different number.) The computer will use this dial-up number as a backup if it cannot reach the primary number.
- g. When you finish, the Primary and Secondary numbers will be displayed onscreen, with the dialing prefix and area code, if entered. Check the entries, and use the buttons to return to any entry that you wish to change. When you are finished, Use **VIEW** and **LOOK BACK** to select **Continue**, and press **↵**.
6. The Time Zone screen will appear next. Use **VIEW** and **LOOK BACK** to select your time zone and press **↵**.
7. The Select Registration Method screen will appear next. Select **Register with Operator Card** and press **↵**.



8. When you are prompted, insert your **Operator Card**. The SmartCard reader will read the card automatically. You will see "Connecting..." onscreen for a about a minute, followed by "Disconnecting... 100% Complete" when the process has finished.

If the call fails to connect, you will see a modem error message (see Connection Troubleshooting on page 66 for information on modem error messages). Press any button to start over from the initial screen. (You will **not** have to re-enter your settings, and you can leave your Operator Card in the SmartCard reader.) If you have repeated connect failures, select a different dial-up number.

9. The Select Cabinet Location screen will appear next. Your existing locations should appear in the list. If you are setting up the cabinet at a new location, proceed to Manually Entering your Location, on page 79. Otherwise continue with Step 10.



10. Use **VIEW** and **LOOK BACK** to scroll through the list, and press **SELECT** to select your location.
11. The next screen will prompt you to enter your cabinet serial number (find this number, starting with "GVR" on a sticker on the back of the cabinet). Use the buttons and/or steering wheel to navigate the onscreen keyboard to select each character. Press **Start** to enter each character. Select **Done** and press **Start** when finished.

You will see "Connecting..." onscreen, followed by "In Progress...". When the process finishes, you will see "Registration Successful." Press any button to return to the Operator Menu.

**Important:** If you never see the Registration Successful screen, this can indicate a problem with registration, possibly an interrupted modem connection. Select Force Call from the Registration Options screen to make sure that your cabinet is able to sync with GLOBAL VR®.

Your cabinet is now registered. It is a good idea to set the sync time on the Registration Options screen so that your cabinets call in to GLOBAL VR® at different times. Also make sure the cabinet will be powered on at the selected sync time.

## Manually Entering your Location

1. If your location is not in the list on the Select Cabinet Location screen, select **New Location** and press **J**. The next screen will show a list of fields requesting information about your location. When you enter this screen, the first field will be pre-selected.



2. Use the **VIEW**, **LOOK BACK**, **J**, and **NOS** buttons and/or steering wheel to navigate the onscreen keyboard, and press **START** to enter each selected character. To make a correction, select the **Backspace** key on the onscreen keyboard and press **START**. When you are finished, select **ENTER** on the onscreen keyboard and press **START**.
3. For Location Type and State, use **VIEW** and **LOOK BACK** to scroll through a list of options and press **START** to select.
4. When you have filled in all of the fields, select **DONE** from the onscreen keyboard and press **Start**. (If you press **Done** before filling out all required fields, the next field that needs information will become selected.)

You will see "Connecting..." onscreen, followed by "In Progress...". When the process finishes, you will see "Registration Successful." Press any key to return to the Operator Menu.

**Important:** If you never see the Registration Successful screen, this can indicate a problem with registration, possibly an interrupted modem connection. Select Force Call from the Registration Options screen to make sure that your cabinet is able to sync with GLOBAL VR®.

Your cabinet is now registered. It is a good idea to set the sync time on the Registration Options screen so that your cabinets call in to GLOBAL VR® at different times. Also make sure the cabinet will be powered on at the selected sync time.





## Chapter 5 — Operator Menu and Game Setup

This chapter describes how to use the Game Operator menu to set up the game or diagnose problems. All game audits, settings, registration, and control diagnostics are accessed from the Game Operator Menu. Refer to Game Operator Menu Flowchart on the following page, for a list of the Game Operator menu screens and available settings.

Press the **red** operator button behind the coin mech door to enter the Game Operator menu.

### Navigating Through the Game Operator Menu Screens







Use the buttons on the driving control panel to navigate, select, and change options, as described in the table below. Onscreen instructions will provide additional information on using each menu.

Button	Function	Comments
	<b>Up</b>	Scroll through lists or settings.
	<b>Down</b>	
	<b>Select</b>	Confirm a setting.
	<b>Back or Exit</b>	Navigate back to the menu list or exit the menu.

The following is an example of how to change a menu option:



Figure 13. Setting Cabinet Volume

1. Use the  and  buttons to navigate and highlight a menu option.
2. Press the  button to select the highlighted option. The game option will turn to red when it is selected.
3. Use the  and  buttons to rotate through the available settings for the selected option, as shown by the arrows in steps 2 and 3 of the picture above.
4. When you reach the setting you want, press the  button again. The game option will now turn back to yellow, and will display the new setting, as shown in step 4 of the picture above.
5. Press the  button to go back to the main menu.

The flowchart below shows the function of each menu in the Game Operator Menu.

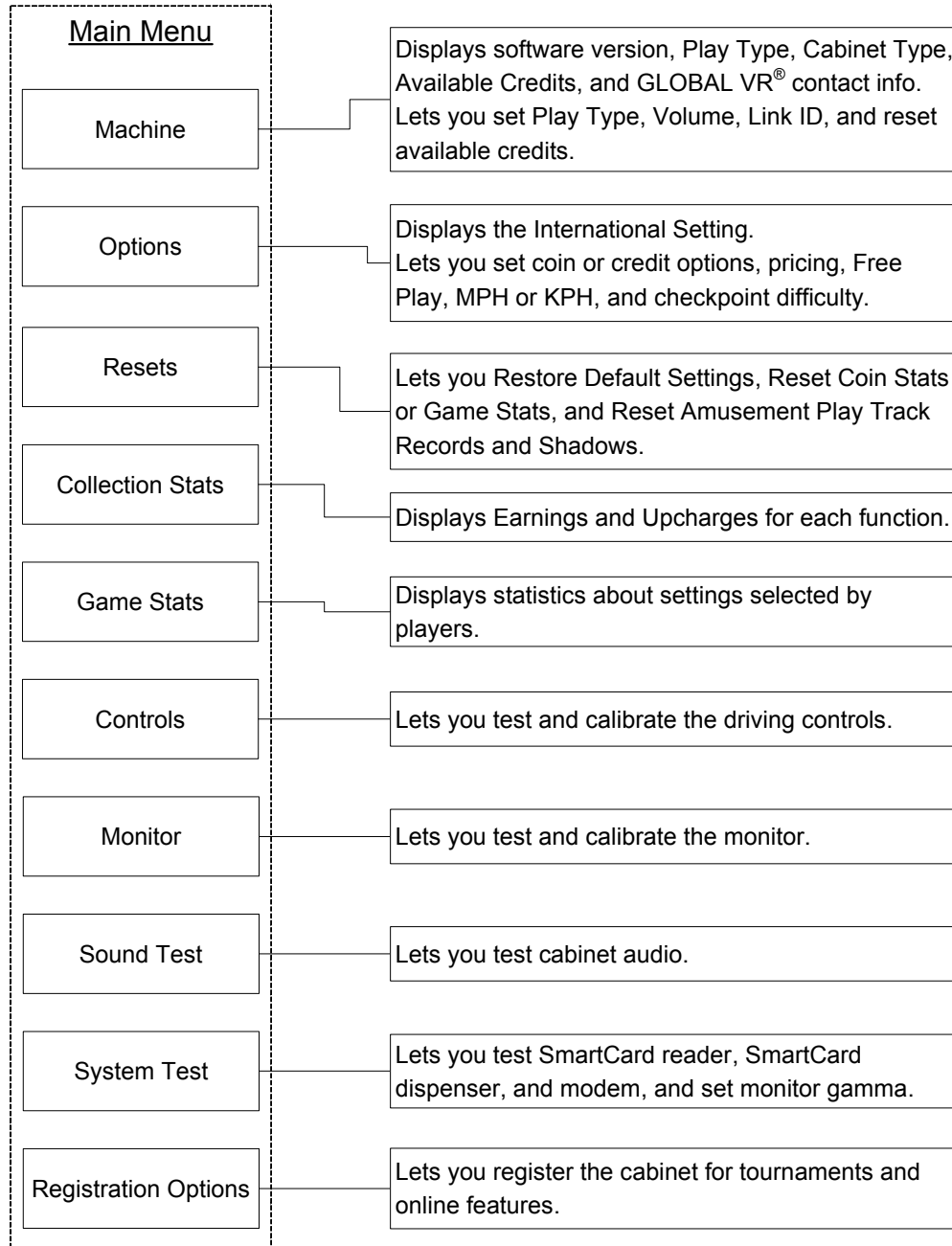

Figure 14. Game Operator Menu Flowchart

## Machine Information Menu



Figure 15. Machine Information Screen

The Machine Information menu is the default screen displayed when you press the Operator Button. It displays important information about the cabinet.

Menu Item	Description	Default Value (as applicable)
<b>Play Type</b>	Sets Play to Amusement Only or Player's Choice.	Player's Choice
<b>Game Version</b>	Displays the game software version installed.	
<b>OS Version</b>	Displays the operating system software version installed.	
<b>Cabinet Type</b>	Displays cabinet type (Sit-Down or Up-Right).	(Set by Dongle)
<b>Available Credits</b>	Displays the number of credits inserted.	
<b>Reset Credits</b>	Highlight and select this button to reset the Available Credits to 0.	
<b>Cabinet Volume Setting</b>	Sets the game audio volume form 0—100% in increments of 5.	55%
<b>Attract Volume</b>	Sets the attract mode audio volume as a percentage of cabinet volume.	95%
<b>Attract Sound Mode</b>	Sets attract mode sound to Always, Sometimes, or Never. The <i>Sometimes</i> setting will play sound in attract mode 1/3 of the time.	Always
<b>Cabinet Link ID#</b>	Sets the ID number used for linking cabinets. Each linked cabinet must have a unique Cabinet Link ID number (1, 2, 3, or 4).	1
<b>Contact Info</b>	Displays GLOBAL VR® contact information.	

## Game and Coin Options Menu

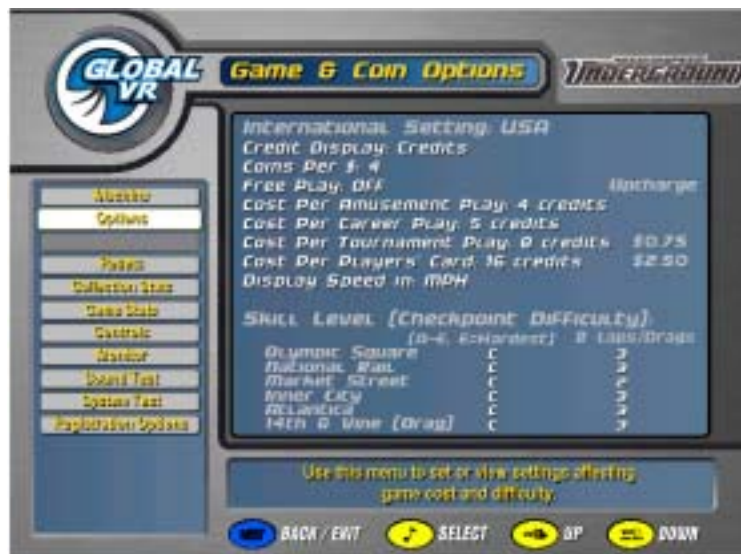

Figure 16. Game and Coin Options Screen

The Game and Coin Options menu is used to set up the type of money or credits used at your location, game pricing, and game-play difficulty.

Menu Item	Description	Default Value (as applicable)
<b>International Setting</b>	Displays the country where the cabinet is operating. This determines the type of money used by the cabinet.	(Set by Dongle)
<b>Credit Display</b>	Sets whether <i>Money</i> or <i>Credits</i> are used to play the cabinet. (This setting affects the display of other items on this screen.)	Money
<b>Coins Per \$ (Currency symbol varies internationally)</b>	Sets how many coin drops it takes to reach a unit of money, typically 4 in the USA (4 quarters per \$) or 1 in the UK (1 1£ coin). Options are 1–20.	USA/CAN: 4 EUR/UK: 1
<b>Free Play</b>	Sets free play <i>ON</i> or <i>OFF</i> .	OFF
<b>Cost Per Amusement Play</b>	Sets number of coins per amusement game. Options are 1–50.*	(Varies by region)
<b>Cost Per Career Play</b>	Sets number of coins per career mode game. Options are 1–50.*	(Varies by region)
<b>Cost Per Tournament Play</b>	Sets number of coins per tournament game. Options are 1–50.* Also shows the Upcharge paid per tournament game. Applies only to National Tournaments run by GLOBAL VR®.	(Varies by region)
<b>Cost Per Players' Card</b>	Sets number of coins to buy a Players' Card. Options are 1–50.* Also shows the Upcharge per Players' Card.	(Varies by region)
<b>Display Speed in</b>	Sets the speedometer to MPH or KPH.	MPH
<b>Skill Level (Checkpoint Difficulty)</b>	Lets you set the <b>Skill Level</b> , by track, from <b>A</b> (easiest) through <b>E</b> (hardest). Easier settings mean more time; harder settings mean less time to reach each checkpoint. <b># Laps/Drags</b> lets you set how many laps or drags players get for each racetrack. Options are 1–5.	C (Medium)  # Laps/Drags varies by track

\*If Credit Display is set to *Money*, this value is displayed in money.

## Reset Stats/Settings Screen and Default Settings



Figure 17. Reset Stats/Settings Menu

- **Restore Default Settings:** Sets the cabinet to the default settings listed below.

Table 1. Default Settings by Region

Setting	US (Dollar)	UK (Pound)	Canada (Dollar)	Europe (Euro)
Credit Display	Money	Money	Money	Money
Coins per \$	4	1	4	1
Free Play	OFF	OFF	OFF	OFF
Cost Per Play	\$1.00	£1.00	\$1.00	€1.00
Game Volume	55	55	55	55
Attract Volume	95%	95%	95%	95%
Skill Level on All Racetracks	C	C	C	C

- **Reset Collection Stats:** Resets the Coin Statistics for the cabinet.
- **Reset Game Stats:** Resets the Game Statistics for the cabinet.
- **Reset Amusement Track Records & Shadows:** Resets the amusement track records and shadows. Tournament records are not affected. You can select **Reset All Tracks**, or reset tracks individually.

## Collection Statistics Screen



Figure 18. Collection Statistics Menu

The Collection Statistics menu shows the total amount of money collected for each type of game, and the last date and time the statistics were reset. The Collection Statistics can be reset through the Resets menu.

## Game Statistics Screens



Figure 19. Game Stats Menu Screens

The Game Statistics menu lets you cycle through three screens with statistics about the options players have selected in Amusement Mode, and their average times for each track. The screens are: Car and Track, Average Times, and Game Features Usage. Press **View** or **Look Back** to move through the pages. You can reset the Game Statistics through the Resets menu.

## Play Control Test



**Note:** A red dot on the lower left corner of the Attract screen indicates a hardware malfunction. The Play Control Test screen shows you which hardware component is not working.

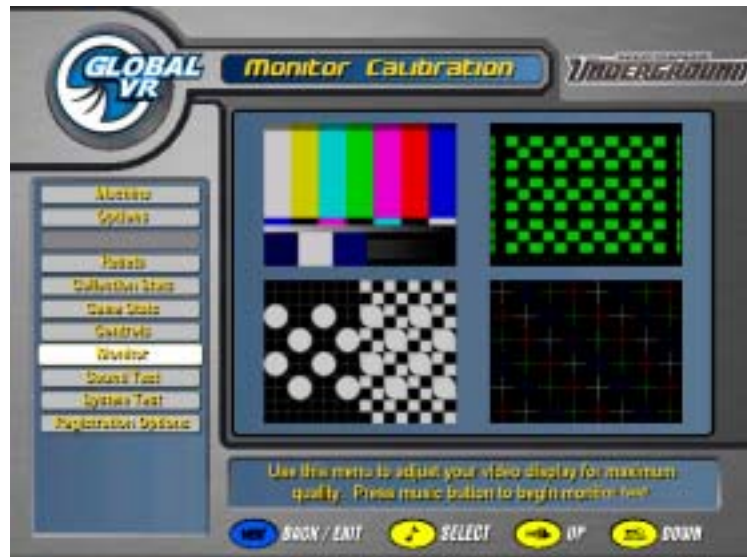

Figure 20. Play Control Test Screen

The Play Control Test screen displays pictures of each driving control, and allows you to test each control, as described below. To exit from this menu, press the **Start** and **View** buttons together. If a component is not functioning, a  symbol will be displayed over it, as shown above.

- **Buttons:** When you press a control panel button, it will light up on the screen.
- **SmartCard Reader:** Indicates whether reader is installed and working.
- **SmartCard Dispenser:** Indicates whether dispenser is installed and working.
- **Steering Wheel:** When you turn the steering wheel to the left or right, the numbers in the graphic should change to indicate the steering wheel position. Full left position should be about  $-127$  and full right position should be about  $127$ . As you turn the wheel, the number change should be smooth and linear. A sudden jump in the numbers, or a different range of numbers, can indicate a bad pot.
- **Gas & Brake Pedal:** When you step on the pedals you will see the same action on-screen. The numbers displayed by the pedals show the value when the pedal is full up, full down, and the current value. The difference between the full up and full down values should be about  $80 (\pm 5)$ . As you press and release the pedals, the number change should be smooth and linear. A sudden jump in the numbers can indicate a bad pot.
- **Shifter:** When you shift through the gears, the current gear number appears on the screen. The screen also displays which shifter micro switches are actuated for each gear. For example, "2 LT DN" means the left and down micro switches are actuated in gear 2. "3 UP" means that only the up micro switch is actuated in gear 3. For more information, refer to Six-Speed Shifter Micro Switch Service on page 79.
- **E-Brake:** If you press the E-Brake button, it will light up on the screen.
- **Credits:** When you insert money into the coin mech or bill validator, the word "CREDITS" will flash, and "OK" will highlight on the screen.
- **Calibration:** To calibrate the steering wheel and pedals, press the **Start** and **NOS** buttons together. The steering wheel will turn by itself during calibration; **do not** touch it during this process. When prompted, step on the gas and brake pedals to calibrate them.
- **Start Button, Leader Light and Brake Light:** When you enter the Controls Menu, the **Start** button, **Leader Light** and **Brake Lights** on the cabinet will blink for several seconds. If any of these lights fails to blink, check the bulb and wiring for the light.
- **Nytrix Card Version:** Indicates version of Nytrix USB/I/O card installed in the computer.

## Monitor Calibration Test

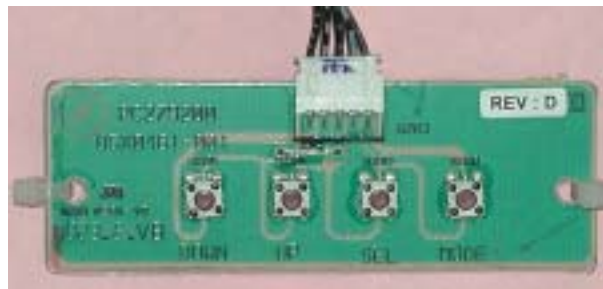

*Figure 21. Monitor Calibration Test Screen*

Press the **Music** button to start the monitor calibration test, and the **View** or **Look Back** button to scroll through the screens. To exit the Monitor Calibration Test, press the **NOS** button or the **Operator** button.

The monitor calibration test cycles through a series of monitor calibration screens. Each screen is designed to help you align the horizontal or vertical sync, or adjust the white balance and color hues.

Use the monitor remote control board buttons to adjust the monitor. The board is located next to the **Operator** button. Use the buttons on the monitor control panel to access a series of menus allowing you to adjust the display size, color, and quality.



*Figure 22. Monitor Remote Control Board*

## Sound Test



*Figure 23. Sound Test Screen*

The Sound Test menu tests the speakers. When you enter the sound test, each speaker will call out its name, one at a time. You should hear the words “Front Left Channel” from the left front speaker, followed by “Center Channel” from the center, and so on. The subwoofer will emit a thumping sound. The Sound test will continue to automatically rotate through each speaker until you press the **NOS** button to exit the test. While the sound test is running, the picture on the screen shows the location of the speaker being tested.

Press the **View** or **Look Back** button to stop the sound rotation and test one speaker at a time. Press **View** to rotate to the next speaker, or **Look Back** to rotate to the previous speaker. Press the **NOS** button to exit the test.

If any sound comes from the wrong speaker, or any speakers are not working, check the connections to the audio amp (see Audio Amp and Speakers Service on page 79).

Refer to Audio Troubleshooting on page 79 for more information on fixing audio problems.

## System Test



Figure 24. System Test Screen

- **Set Video Gamma:** Adjusts the overall brightness of the image. Default is 1.00.
- **Test Card Reader:** Insert an Operator or Players' SmartCard, and then select this option. If the SmartCard reader is working properly, the screen will indicate the type of card inserted and the card number. For Players' Cards, the name of the owner will also be shown. This can be useful for finding the owners of lost cards.
- **Test Card Dispenser:** If a card dispenser is installed, select this option to dispense a card and confirm the dispenser is working.
- **Test Modem:** Forces a call to verify modem function. The screen will indicate whether the modem connected successfully.

## Registration Options

The Registration Options screen allows you to register, unregister, or change the settings the cabinet uses for syncing with GLOBAL VR. This screen also provides valuable information about a registered cabinet. Refer to Chapter 4 — Setting Up Tournament Play on page 79 for registration instructions.



Figure 25. Registration Options Screen

### Buttons

- **Cabinet Registration** or **Unregister Cabinet**: This button will change depending on whether your cabinet is registered. If you restore the software on a cabinet using the System Recovery disk, this button will change to **Cabinet Restore**. Selecting the **Cabinet Restore** button will cause the cabinet to call in to GLOBAL VR<sup>®</sup> and use information on your game dongle to retrieve your registration settings.
- **Force Call**: This button causes the cabinet to call in to GLOBAL VR<sup>®</sup>. Use this if the cabinet fails to sync at the normal time, or to test your connection.
- **Edit Dial-In Numbers**: Use this button to change the phone number the cabinet uses to connect to the Internet, or to switch between dial-up and broadband. If you have repeated connection problems, try a different local number.
- **Activate Operator Card**: Use this to create another Operator Card.
- **Call Sync Log**: Select this to view the list of calls the cabinet has made to GLOBAL VR<sup>®</sup>, and confirm call success or get information about modem errors.
- **Sync Time**: Select this button to change the time the cabinet syncs with GLOBAL VR<sup>®</sup>. Select a time when the cabinet is powered ON, and stagger the time so that all of your cabinets do not try to dial in at the same time.
- **Time Zone**: Displays the selected time zone and allows you to change it.

### Informational Text

- The upper right side of the screen shows the Cabinet Registration Status, Cabinet ID Number used for your account, and Cabinet Serial Number.
- The lower part of the window shows information about the last call made by the cabinet to GLOBAL VR<sup>®</sup>. If there was a problem syncing, the Modem Error Code may help you solve the problem. Refer to Connection Troubleshooting on page 79 for more information.

## Chapter 6 — System Recovery and Game Install CDs



Follow the instructions below if you need to re-install the *Need for Speed™ Underground* software on your cabinet. **Total installation time is about 30 minutes.**

### Using the System Recovery CD

**Important:** When you use the System Recovery Disk, you will erase all game settings and history for the coin and game audits that are stored in the game software. It is advisable to contact Technical Support before using the System Recovery Disk to resolve a problem.

1. If the cabinet is linked, disconnect the Ethernet cable from the back of the cabinet.
2. Insert the **System Recovery Disk** in the CD-ROM drive and power the cabinet OFF and then ON. When the computer reboots, the CD should run automatically (wait about 30 seconds). You will see the hard-drive image process screen.
3. When the CD has finished running, you will be prompted to remove the CD and reboot the computer. **Do not** insert the Game CD yet! Wait for about 2 minutes while the software finishes the installation. When you see a desktop screen with the GLOBAL VR® logo, the Operating System installation is complete. Proceed to run the **Game Install CDs**.

### Using the Game Install CDs

**Important:** All linked cabinets must run the same game software version.

1. With the cabinet powered ON and the computer booted, insert the CD labeled **Game Install Disk 1 of 2**. The CD will automatically run (wait about 30 seconds). You will see a series of screens as the software copies components and files to the hard drive. The process will take about 10 minutes.
2. When the first CD is complete, the computer will eject the CD and prompt you to insert Disk 2. Insert **Game Install Disk 2 of 2**. The computer will automatically copy the remaining files from Disk 2 and reboot the computer when finished. You may see a blank screen for about a minute.
3. Once the game has restarted, remove the CD. Keep the System Recovery and Game Install CDs in a safe place in case you need them in the future.
4. When the game starts it will need to calibrate the gas, brake, and steering pots. The steering will self-calibrate (do not touch the wheel while it is calibrating). When prompted, press and hold the gas and brake for five seconds to set the calibration limits. Once the calibration is complete, the attract movie will begin. Start and play one game to finalize hardware calibration.
5. Once the software install is complete, press the Operator button and set the sound volume levels, cabinet Link ID Numbers, and any other cabinet settings. Reconnect the Ethernet cable if used.
6. For registered cabinets, select **System Recovery** from the Registration Options screen of the Operator Menu. Follow the onscreen instructions. The cabinet will call in to GLOBAL VR® and retrieve the registration information using the ID stored in the game dongle.

## Chapter 7 — Service and Repair

---

**Caution:** GLOBAL VR® assumes no liability for any damage or injuries incurred while servicing the cabinet. Only qualified service personnel should perform service and installation of cabinet hardware.

Always turn the cabinet OFF and disconnect the AC power cord before performing any repair work.

To prevent electrostatic discharge (ESD) damage, handle PCBs by the edges only and use a grounding wrist strap or similar precaution.

Please read the service instructions before working on the cabinet.

### Opening the Control Panel

To gain access to the force-feedback motor and driving control buttons, remove the four (4) T-25H Security Torx bolts from the Driving Control Panel as shown by the arrows in the picture below. The Driving Control Panel assembly is mounted to a hinge and will fold down.

**Note:** Deluxe cabinets have five (5) bolts securing the control panel.



*Figure 26. Opening the Control Panel*

## Force-Feedback Steering System Service

The major components of the steering system are listed below. The figure that follows shows the harnessing of the force-feedback steering system.

- Steering Wheel
- Force-Feedback PCB (Blue Board, part # COEM-6040-245)\*
- Force-Feedback Motor Controller PCB (Green Board, part # COEM-6052)\*
- +24 VDC Power Supply
- Force-Feedback Motor
- 5 K $\Omega$  Steering Pot (Potentiometer)

\*At the time of this writing, a single-PCB Force-Feedback system was just becoming available. This single board (Part #: COEM-ELEC-AW-SB-GVR) is completely interchangeable with the two PCBs in the current systems. If you receive the single board as a replacement part, remove both existing PCBs.

The force-feedback steering system is powered by the +24 VDC power supply. The power supply connects to the Force-Feedback PCB. The PCB routes the power to the force-feedback steering motor.

**Caution: Do not connect the power supply directly to the force-feedback motor. Doing this will damage the motor and the power supply.**

The Force-Feedback Motor Controller PCB is connected to the Force-Feedback PCB, the computer USB port, and the 5 K $\Omega$  steering pot. This card manages communications between the steering pot, the computer, and the force-feedback card. The steering pot sends the computer the steering wheel position as the player drives, and the computer sends back instructions for controlling the force-feedback motor.

A faulty cable or steering-system component can cause steering problems. Refer to the Control Troubleshooting table on page 79 for help with diagnosing steering problems.

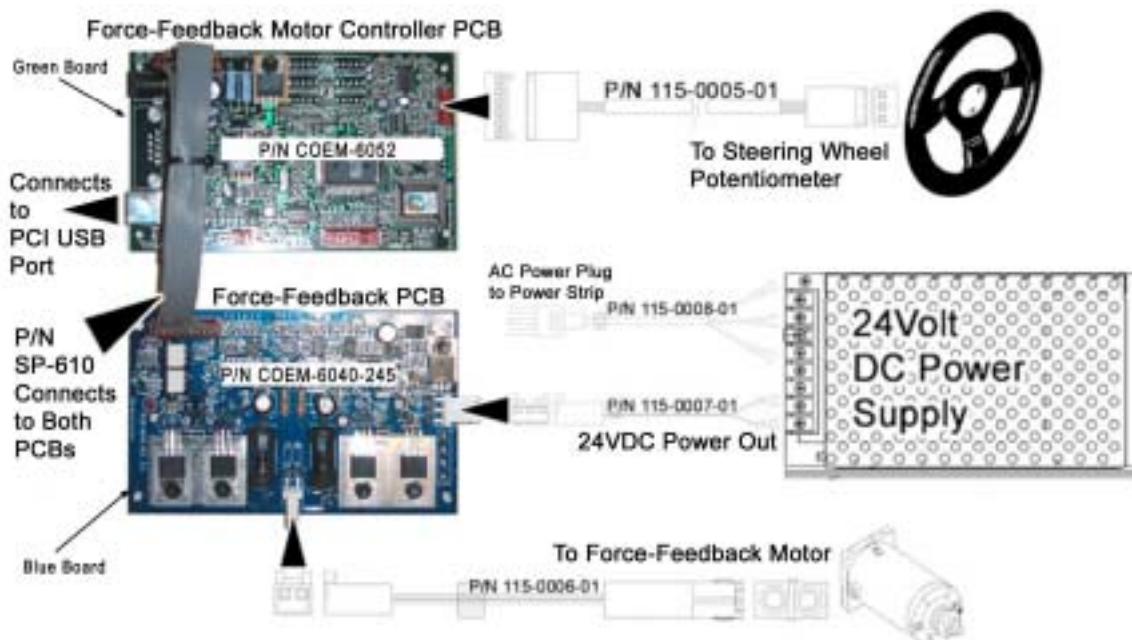

Figure 27. Force-Feedback Steering System Harnessing Diagram

## 5 K $\Omega$ Steering Pot (Potentiometer) Replacement

To test a pot, use the Play Control Test in the Operator Menu (see page 79). While turning the wheel, the change in the numbers displayed onscreen should be smooth and linear, with no jumps.

You can also power off the game and test resistance at the pot. While turning the wheel, you should see a steady linear increase or decrease in resistance, with no jumps.

To replace a pot, refer to Figure 28 and perform the following steps:

1. Using a 7/64 Allan wrench, loosen the set screw from the steering column and remove the bracket with the 5 K $\Omega$  steering pot attached.
2. Using a 1/2-inch wrench, remove the nut and lock washer from the bracket and remove the pot.
3. Reverse these steps to install the new pot. Install the pot with the plastic pin through the small hole in the bracket, as shown in Figure 28 below.
4. Calibrate the steering from the Play Control Test in the Operator Menu after replacing the pot.

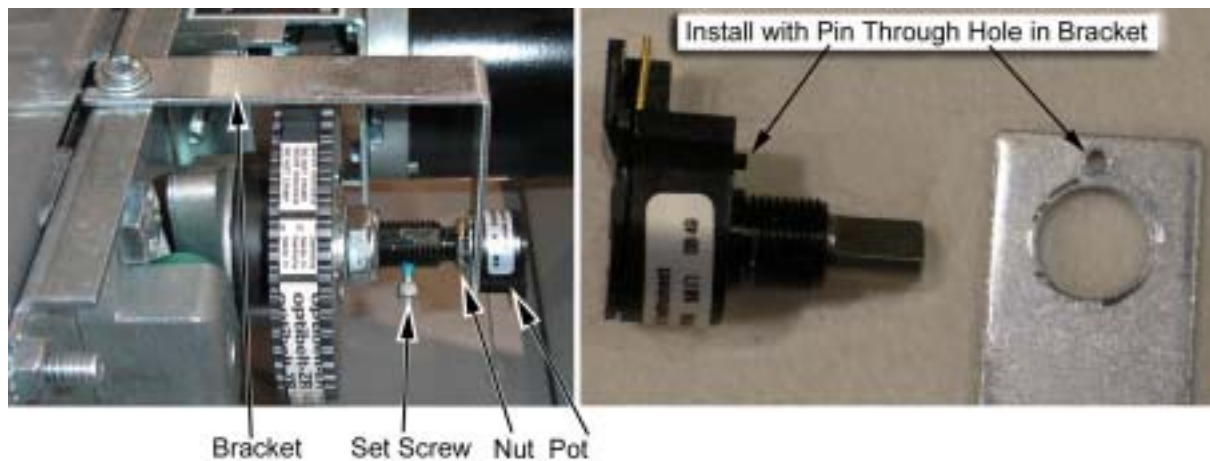

Figure 28. Replacing the 5 K $\Omega$  Steering Pot

## Force-Feedback Belt or Motor Replacement

Refer to Figure 28 above, and Figure 29, and perform the following steps to remove the force-feedback belt for repair. Always replace the belt if it looks cracked or worn.

1. Using a 7/64 Allan wrench, loosen the set screw from the steering column and remove the bracket with the pot attached (see Figure 28).
2. Loosen the four (4) 3/8" motor mount Kep nuts that secure the force-feedback motor to the frame (see Figure 29).
3. Using a 10mm socket wrench, loosen the belt tension adjustment bolt several turns until you can slip the belt off of the motor and steering gears (see Figure 29).
4. To replace the motor, remove the four (4) 3/8" Kep nuts that you loosened in step 2, and remove the motor.
5. Reverse these steps to re-install the motor and belt. When installing the belt, tighten the tension adjustment bolt until the belt is fully stretched, and then loosen the bolt by 1/2 turn.
6. Calibrate the steering from the Operator Menu after servicing the belt or motor.



Figure 29. Servicing the Force-Feedback Motor

### Force-Feedback PCB Replacement

**Caution:** To prevent electrostatic discharge (ESD) damage, handle PCBs by the edges only and use a grounding wrist strap or similar precaution.

If the steering pulls to one side, this could indicate a bad force-feedback motor controller card. Use the following steps to replace one or both force-feedback PCBs.

**Important:** Part # COEM-ELEC-AW-SB-GVR is a single-PCB system that replaces **both** COEM-6052 and COEM-6040-245.

1. Disconnect the cabinet from AC power.
2. Disconnect all cables from the PCB.
3. Remove the four screws that secure the PCB to the cabinet.
4. Reverse these steps to install the new PCB.
5. Calibrate all analog inputs from the Operator Menu after replacing the PCBs.

### Driving Control Panel Button Service

The buttons on the cabinets are illuminated with 5-volt C555 bulbs. Refer to Figure 30 and perform the following steps to replace the button bulbs and micro switches:

1. Disconnect the cabinet from AC power.
2. Open the driving control panel assembly as described on page 79.
3. To remove a micro switch, gently rock it to the side and remove it from the housing. Remove the wires and install them on the same connectors on the new micro switch.
4. To replace a bulb, gently rock the white plastic bulb housing from side to side to pop it out of the button housing.
5. To remove a bulb, pull it straight out of the bulb housing.

**Caution:** Do not connect the 5-volt lamp power wire to the micro switch. This can damage the USB I/O card in the computer.

6. When connecting the wiring to the micro switch and bulb, refer to the labels on the wires to make sure the connections are correct.



Figure 30. Replacing Button Lamps

## Pedal Assembly Service

Perform the following steps to remove the pedal assembly. It is removed and installed as one unit.

1. From inside the cabinet, disconnect the pedal cable assembly from the wire harness, as shown by the arrow in the picture below.
2. Remove the four (4) 1/4-20H Security Torx bolts, as shown by the arrows in the picture below.
3. Pull the pedal assembly towards the seat to remove.

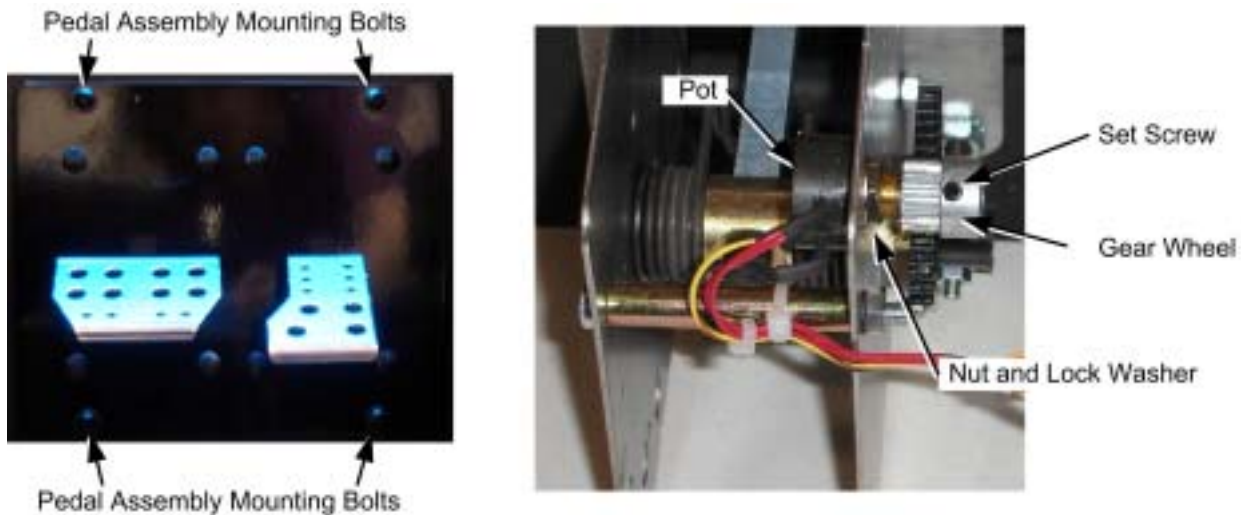

Figure 31. Pedal Assembly Details

## 5 K $\Omega$ Gas and Brake Pot (Potentiometer) Replacement

To test a pot, use the Play Control Test in the Operator Menu (see page 79). When you press and release the pedals, you should see a steady increase or decrease in the numbers displayed onscreen, with no jumps.

You can also power off the game and test resistance at the pot. When you press and release the pedals, you should see a steady linear increase or decrease in resistance, with no jumps.

To replace a pot, refer to Figure 31 above and perform the following steps:

1. Using a 7/64 Allen wrench, loosen the set screw from the gear wheel and remove the gear wheel, as shown in the picture above.

2. Using a 1/2" wrench, remove the nut and lock washer that secure the pot to the frame.
3. Install the new pot with the same orientation. Make sure that the plastic keys on the pot match with the metal.
4. Re-install the lock washer and nut, being careful not to over-tighten.
5. Re-install the gear wheel and tighten the set screw.
6. Calibrate all analog inputs from the Play Control Test in the Operator Menu after replacing the pot.

## Six-Speed Shifter and E-Brake Service

The sections that follow describe repair and replacement of the six-speed shifter.

### Six-Speed Shifter Replacement

Perform the following steps to remove the shifter from the seat for replacement or repair.

1. Remove the four (4) T-10H Security Torx screws from the top of the shifter assembly and carefully pull the shifter up out of the housing.
2. Disconnect the Molex connector from the shifter.
3. Reverse these steps to re-install the shifter.

### Six-Speed Shifter Micro Switch Service

The shifter uses four miniature micro switches to relay the shifter position to the computer.

Figure 32 shows micro switch placement, and which micro switches are actuated for each gear.

By using the chart, you can determine which switch may be faulty. For example, if gears 1 and 2 stop working, the problem is probably with the Left micro switch.

The Controls screen in the Operator Menu also displays which micro switches are actuated as you shift through the pattern.

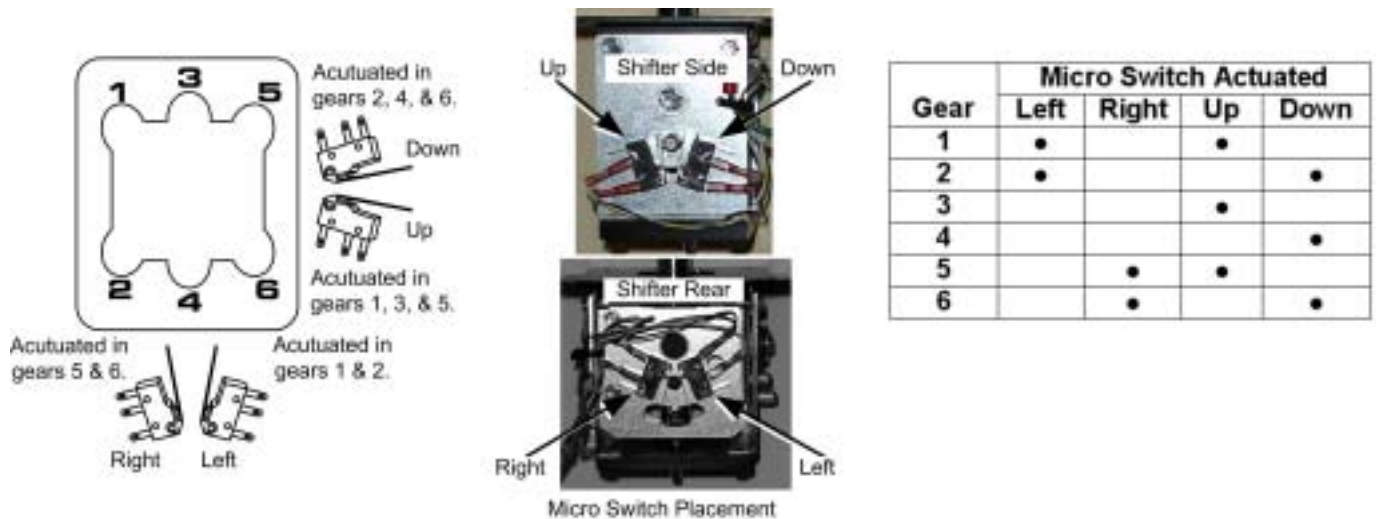

Figure 32. Shifter Pattern and Micro Switch Actuation

Perform the following steps to replace a micro switch:

1. Remove the shifter assembly from the housing as described on page 79.
2. Disconnect the two wires from the micro switch.
3. Remove the two screws that secure the micro switch to the shifter and remove the switch.
4. Reverse these steps to install the new micro switch.

### **Shifter Bottom Plate Replacement**

If the shifter does not go into certain gears, or slips out of gear, the bottom plate may be worn. Perform the following steps to replace the bottom plate:

1. Remove the shifter assembly from the housing as described on page 79.
2. Remove the four screws that secure the bottom plate and remove the plate.
3. Reverse these steps to install the new bottom plate.

### **E-Brake Button Service**

1. Remove the shifter assembly from the housing as described on page 79.
2. To replace the button or change the bulb, refer to Driving Control Panel Button Service on page 79. The E-Brake button is assembled the same as the control panel buttons.

### **Driving Seat Slide Assembly Replacement**

To replace the slide assembly, refer to Figure 33 and perform the following steps:

1. Remove the four (4) T-15 Torx screws that secure the plastic shifter cover to the pedestal.
2. Remove the five (5) T-27 Torx bolts that secure the shifter housing to the pedestal, and remove the shifter assembly.
3. Remove the six (6) Torx bolts that secure the seat mounting plate to the wooden pedestal.
4. Lift the seat assembly off the pedestal and place it on its side.
5. Remove the four bolts from the bottom of the seat mounting plate. These bolts secure the seat mounting plate and slide assembly in place.
6. Remove the seat mounting plate, slide assembly, and washers. Note the placement of each component for reassembly.
7. Reverse these steps to re-assemble the seat assembly. Refer to Figure 33 for the placement of each component.

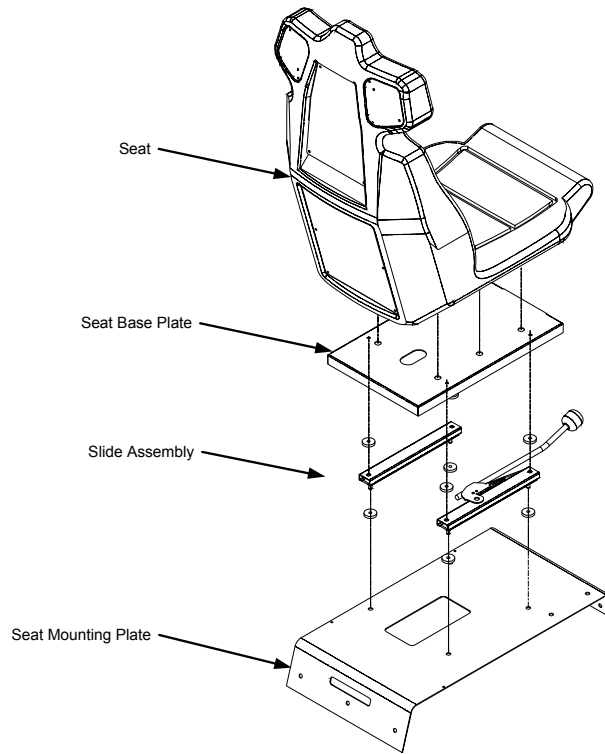
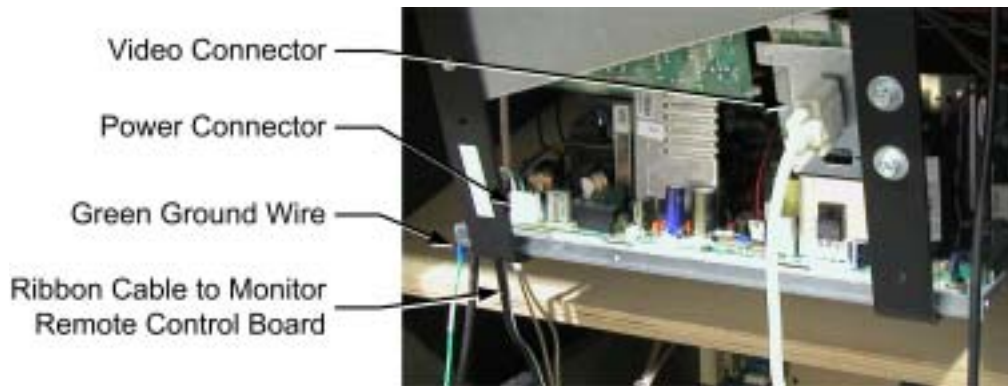

*Figure 33. Seat Slide Assembly Replacement*

## Wells-Gardner® Monitor Replacement

Perform the steps that follow to remove the monitor from the cabinet for service or replacement. Be sure to follow all safety precautions while working with a monitor.

**Tip:** When removing the monitor from the cabinet, it is always best to have two people to support the weight of the monitor.



*Figure 34. Cable Connections to the Monitor Chassis*

1. Turn the cabinet OFF and disconnect the AC power cord.
2. Refer to Figure 34 and disconnect the following cables:
  - VGA Video cable from the back of the Monitor.
  - Monitor remote control board cable from the board mounted near the Operator button. Coil this cable and tie it to the monitor to prevent it catching while the monitor is being removed.
  - Power cable that connects to the monitor chassis PCB, located on your left as you face the monitor rear.
  - **Green** ground wire from the monitor frame near the power connection.
3. Inspect the disconnected cables and monitor frame to make sure that there are no wire ties holding the monitor to the cabinet.
4. Open the driving control panel (see Opening the Control Panel on page 79).
5. Remove the three screws from the marquee support brace and fold the marquee down on its hinge.
6. Remove the two (2) #10 x .75 wood screws that secure the monitor bezel to the top of the cabinet and remove the monitor bezel.
7. Remove the four (4) 1/4-20 monitor mounting nuts, as shown in Figure 35.



Figure 35. Monitor Mounting Nut Locations



**DANGER: Components in the monitor chassis can be charged with a VERY HIGH VOLTAGE even when powered OFF.**

**The monitor is very heavy. Two-person lifting is advised.**

8. Carefully remove the monitor through the front of the cabinet and set it in a safe place. Most of the weight of the monitor is in the CRT at the front of the monitor.
9. Reverse these steps to re-install the monitor. Always clean the front of the CRT and the clear display shield before re-installing.
10. After replacing a monitor, run the Monitor Calibration Test from the Operator Menu Diagnostics to verify proper operation (see Monitor Calibration Test on page 79).

## Wells-Gardner® Monitor Chassis PCB Removal

You can uninstall the monitor chassis PCB if you should have problems with just the PCB.

**Caution: Only a certified technician should attempt to remove or service the Monitor PCB. GLOBAL VR® assumes no responsibility for damage while removing the PCB.**

**Caution: To prevent electrostatic discharge (ESD) damage, handle PCBs by the edges only and use a grounding wrist strap or similar precaution.**

1. Turn the cabinet OFF and disconnect the AC power cord.
2. Remove the four nuts that hold the monitor chassis to the monitor frame.
3. Remove the two 4/40 Jack nuts that hold the video signal PCB to the monitor frame. See the figure below.



*Figure 36. Removing the Monitor PCB Mounting Hardware*

4. Disconnect the Chassis Neck PCB from Chassis Tube Neck of the CRT by pulling back on the Chassis Neck PCB. You will need to slide the Chassis Neck PCB to the side to clear the Chassis Tube Neck.



---

**DANGER: The Second Anode Lead (H.V. CRT Feed) can be charged with a VERY HIGH VOLTAGE even when powered OFF.**

---

5. Disconnect the second anode lead that connects to the CRT just above the Chassis Tube. Be very careful as the second anode lead can be charged with a VERY HIGH VOLTAGE even when powered OFF. Pinch the gray rubber flange and slightly push in to un-hook the metal prongs that hold the second anode lead to the CRT, shown by the arrows in Figure 37.

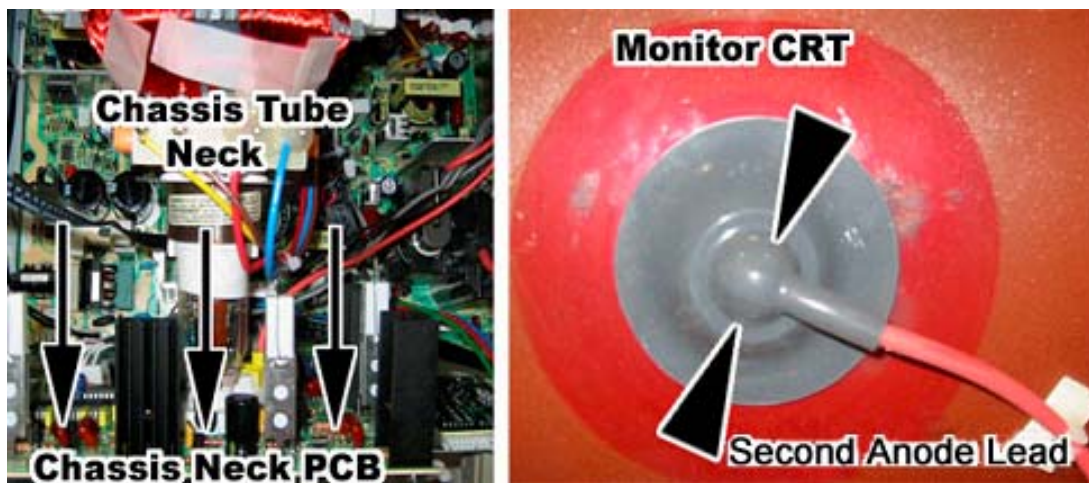

Figure 37. Disconnecting the Chassis Neck PCB and Second Anode Lead

6. Refer to Figure 38 to disconnect the next three cables:
  - a. Disconnect the CRT 2-wire ground cable that connects to the Chassis Monitor PCB (Item 1 below).
  - b. Disconnect the CRT 2-wire ground cable that connects to the Chassis Neck PCB (Item 2 below).
  - c. Disconnect the Color and Sync 4-wire cable that connects from the Chassis Tube Neck to the Monitor chassis PCB (Item 3 below). Note the color alignment of this connector for installing the new monitor chassis PCB.



Figure 38. Monitor PCB Cables

7. You can now slide the monitor chassis PCB and other PCBs out the side of the monitor chassis as one unit.

## Audio Amp and Speakers Service

The u5.1 audio amp supports 6-channel 5.1 Surround Sound. The audio amp is powered by the +5/+12 volt DC power supply through a standard PC power connector.

The volume level for each channel on the audio amp can be manually adjusted using a small screwdriver to turn the pots, shown in Figure 39. For best results, turn each pot counterclockwise to turn the volume levels all the way down. Next, turn each pot 1/5 of a turn clockwise to bring the volume levels up. Fine-tune the sound levels for your location from this point.

Use the Sound Test screen in the Operator Menu to test each speaker on the cabinet.

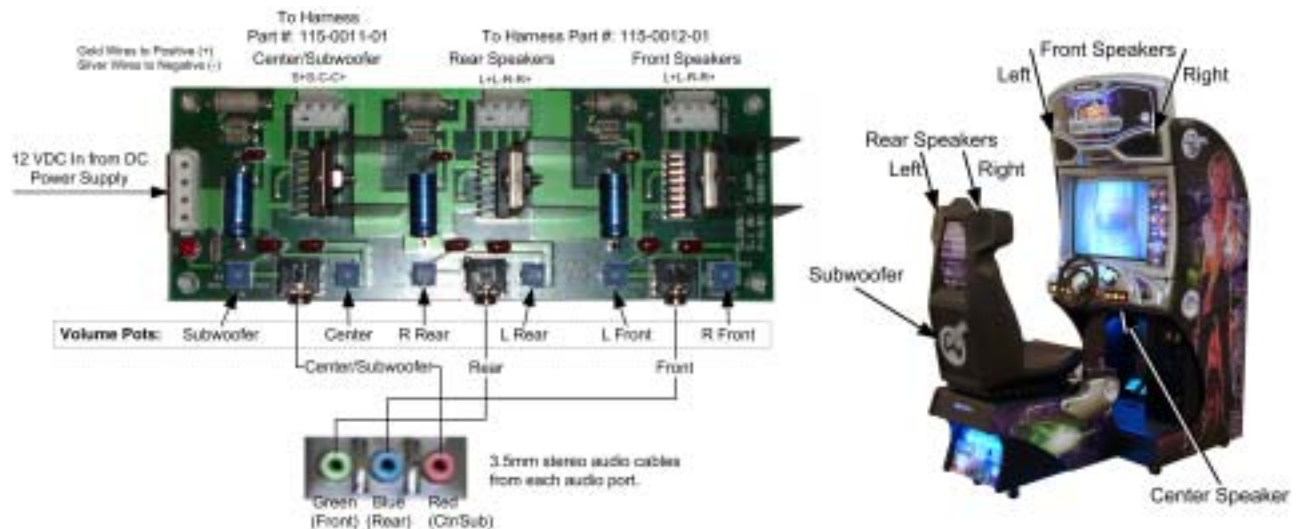

Figure 39. Audio Amp Connections, Volume Adjustment, and Speaker Location

Three 3.5 mm stereo audio cables connect the computer audio ports to the audio amp. Each audio port on the computer is color coded to help identify the channel.

- The **green** audio port is front speakers, left and right.
- The **blue** (middle) audio port is rear speakers, left and right.
- The **red** audio port is center channel and bass speaker (subwoofer).

Each speaker is connected to the corresponding speaker output on the audio amp. The figure above shows the location of each speaker.

### Audio Amp PCB Replacement

**Caution:** To prevent electrostatic discharge (ESD) damage, handle PCBs by the edges only and use a grounding wrist strap or similar precaution.

1. Disconnect the power harness, speaker wires, and 3.5mm audio cables from the audio amp PCB.
2. Use a small Phillips screwdriver to remove the four (4) screws holding the PCB to the cabinet. Always keep the audio amp PCB inside an ESD anti-static bag when not installed in the cabinet to prevent electrical damage.
3. Reverse these steps to re-install the audio amp PCB.

## Front (Marquee) Speaker Replacement

The front speakers are located on either side of the marquee.

1. Remove the three (3) 1/4-20H Torx security screws that secure the speaker grill to the cabinet.
2. Remove the four (4) screws that secure the speaker to the cabinet.
3. Remove the wires from the speaker and install them to the same connectors on the replacement speaker.
4. Reverse these steps to re-install the speaker.

## Center Speaker Replacement

The center speaker is located behind the control panel.

1. Open the control panel as described on page 79.
2. Remove the four (4) 1/4-20H Torx security screws that secure the speaker to the cabinet.
3. Remove the wires from the speaker and install them to the same connectors on the replacement speaker.
4. Reverse these steps to re-install the speaker.

## Rear (Seat) Speaker or Subwoofer Replacement

The rear speakers are located behind the two small grills at the top rear of the seat. The subwoofer is located behind the large grill at the center rear of the seat.

1. Remove the four (4) 1/4-20H Torx security screws that secure the speaker grill to the back of the seat.
2. Remove the four (4) screws that secure the speaker or subwoofer to the seat.
3. Remove the wires from the speaker or subwoofer and install them to the same connectors on the replacement speaker or subwoofer.
4. Reverse these steps to re-install the speaker or subwoofer.

## Computer Replacement

**Caution: The computer is serviced as one unit. YOU WILL VOID YOUR WARRANTY if you open the computer without direct authorization from the GLOBAL VR<sup>®</sup> Technical Support staff.**

Perform the following steps to remove the computer from the cabinet:

1. Disconnect the cabinet from AC power.
2. Disconnect all of the cables from the computer.
3. Remove the Game Dongle and keep it with your cabinet. **Do not** ship the game dongle with the computer. It contains information that needs to stay with the cabinet.
4. Refer to Figure 40 on page 79. The computer is mounted from under the shelf by three (3) 10-32 x 1 1/2" bolts that screw into the computer feet. Remove the bolts from under the shelf.
5. Remove the two wood screws from the back of the wooden brace on top of the computer.



*Figure 40. Computer Mounting*

6. Reverse these steps to replace the computer. Make sure that the computer air vents are not blocked. There is an air vent under the bottom front panel of the computer that is easily blocked by padding or debris. Be sure to reconnect your Game Dongle.
7. After replacing a computer, be sure to calibrate the pedals and steering (see page 79). Set up your cabinet from the Operator Menu (see Chapter 5).
8. If your cabinet is registered, select **System Recovery** from the Registration Options screen of the Operator Menu. Follow the onscreen instructions. The cabinet will call in to GLOBAL VR<sup>®</sup> and retrieve the registration information using the ID stored in the game dongle.

When shipping the computer, always use plenty of padding and protection. GLOBAL VR<sup>®</sup> recommends shipping the computer in a box with three inches of foam padding on all sides.

**Caution: Shipping the computer without enough padding can VOID THE WARRANTY if the computer is visibly damaged from shipping.**

## Coin Mech Replacement

Perform the following steps to remove the coin mech. You can replace the coin mech with any standard arcade coin mech.

1. Unscrew the thumbscrews on the latches as shown by the arrows in step 1 of the figure below.
2. Slide the latches apart from each other and remove the Coin Mech as shown in steps 2 and 3.
3. Reverse these steps to re-install a coin mech. It is important to verify the operation of the newly installed coin mech with both good and bad coins.

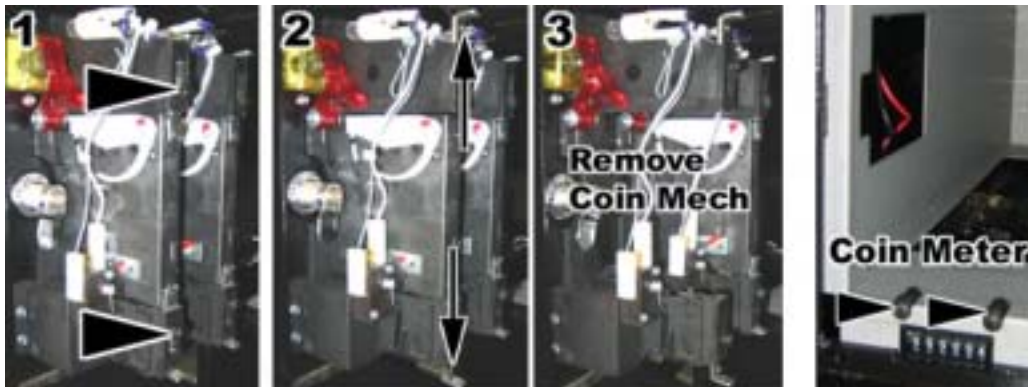

Figure 41. Servicing the Coin Mech and Coin Meter

## Coin Meter Replacement

The coin meter is located in the bottom left-hand corner of the cash box. Perform the following steps to remove the coin meter:

1. Turn the cabinet OFF and disconnect the AC power cord.
2. Remove the two Phillips screws holding the coin meter to the cabinet and remove the coin meter.
3. Cut the two wires from the coin meter and strip the ends of the wires to attach the new meter.
4. Use two butt splices to connect the wires to the new coin meter.
5. Use the two screws to install the new coin meter.

## Dollar Bill Validator Replacement

1. Disconnect the dollar bill validator control harness and ground wire from the cabinet.
2. Remove the cash box from the dollar bill validator.
3. Remove the four nuts that hold the dollar bill validator in place.
4. Reverse these steps to install a new unit. Make sure that the dollar bill validator ground wire is connected to the cabinet and the cabinet is properly grounded or the unit will not work properly.
5. Refer to the following figure to set the DIP switches.

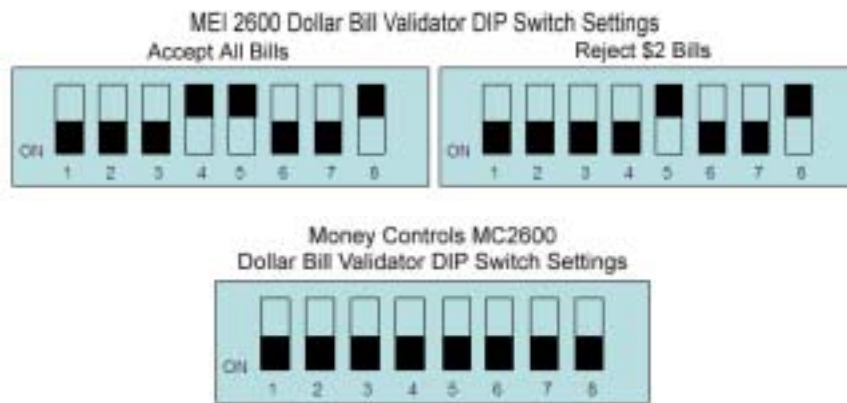

Figure 42. Dollar Bill Validator DIP Switch Settings

## SmartCard Reader Replacement

The SmartCard reader is located to the right of the driving control panel. It is mounted to two plastic blocks that are designed to minimize ESD interference. Perform the following steps to replace the SmartCard reader:

1. Open the control panel as described on page 79.
2. Disconnect the cable from the SmartCard reader.
3. Remove the two (2) screws that secure the SmartCard reader to the ESD-protective blocks.
4. Slide the SmartCard reader out of the control panel.
5. Reverse these steps to install the new SmartCard reader.

## SmartCard Dispenser Service

**Important:** The dispenser will not work unless it is fully closed and in a vertical position (no more than a 5-degree angle), with the back cover in place. If you reboot the computer only, rather than power cycling the cabinet, the dispenser may dispense a card.

Perform the following steps to open the dispenser to refill or count the SmartCards.

1. Open the SmartCard dispenser door with the key; it will rotate downward on a hinge.
2. Slide and lift the back panel as shown in Figure 43.
3. Insert SmartCards as shown, with the magnetic stripe down. The dispenser will hold up to 185 SmartCards.
4. Reverse these steps to close the dispenser.

## SmartCard Dispenser Replacement

1. To remove the dispenser from the cabinet, disconnect the wire harness and remove the four Kep nuts that secure the dispenser to the door.
2. When you re-install the dispenser, the plastic lip around the card slot must line up with the hole in the door. When properly installed, the plastic around the slot is flush with the face of the door.

**Important:** An inverting transistor is built into the card dispenser harness. To ensure proper operation, replace the harness with the same part number only.

After servicing the SmartCard dispenser, always test it from the System Test in the Operator Menu.

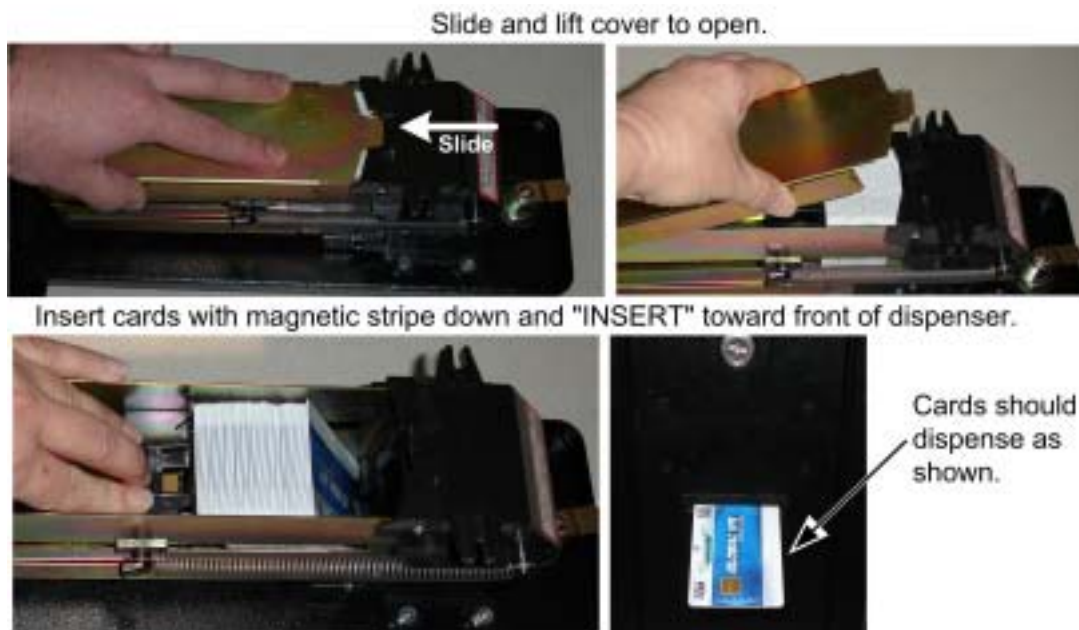

Figure 43. Filling the SmartCard Dispenser

## Power Distribution Service

### AC Power Plate

The AC power plate provides the external AC power, modem (phone), and Ethernet connections.

AC power from the power plate is connected to a 7-outlet AC power strip/surge suppressor in the cabinet. An AC EMI Filter in the AC power plate removes the electrical noise that could cause interference with the hardware inside the cabinet.

**Caution: The cabinet must be connected to a secure ground to function properly.**

Ground wires from system components must be securely connected to the ground lug on the power plate, as shown in Figure 44. Components must **not** be grounded to the power plate mounting bolts.

The **Ethernet** and **Phone** ports on the power plate are connected to the appropriate ports on the system computer (see Figure 59 on page 79).



Figure 44. AC Power Plate (Standard Cabinet)

## AC Power Strip Replacement

The AC power strip provides power to all of the components in the cabinet. Perform the following steps to replace the power strip:

1. Turn the cabinet OFF and disconnect the AC power cord.
2. Disconnect all components from the power strip.
3. Disconnect the power strip from the AC power plate terminals.
4. Remove the power strip; it is held in place with Velcro<sup>®</sup>.
5. Replace the power strip with an appropriate unit from GLOBAL VR<sup>®</sup>. Do not attempt to use a different power strip. Be sure to connect each wire to the correct terminal. (See Power Distribution Diagram on page 79.)

**Caution:** Be sure to connect each wire to the correct terminal. The ground wire must be securely connected to the ground lug on the power plate or the game may not function properly.

## DC Power Supplies (+24 and +5/+12 VDC)

The cabinet has two DC power supplies. The +24 VDC supply powers the force-feedback steering system. The +5/+12 VDC supply powers the audio amp, brake light, and cold cathode lights. If your cabinet loses audio and lighting at the same time, it is likely that there is a problem with the +5/+12 VDC power supply.

**Important:** Connect **only** the steering components to the +24 VDC Power Supply. **Do not use** the +12 VDC Terminals on the +24 VDC Power Supply.

Perform the following steps to replace a DC power supply:

1. Turn the cabinet OFF and disconnect the AC power cord.
2. Unplug the DC power supply from the power strip.
3. Disconnect the wires from the DC power supply terminals.
4. Remove the two Phillips screws holding the power supply to the cabinet. Be careful not to remove the screw that secures the terminal plate to the DC power supply.
5. Before installing the new power supply, connect a volt meter and adjust the output voltage from the pot on the front of the power supply as follows:
  - **+5/+12 VDC power supply:** Set the +5VDC output between +5.05 and +5.1 VDC.
  - **+24 VDC power supply:** Set the +24 VDC output to +24 VDC.
6. Reverse the steps above to install the new power supply. Check the labels on each wire and be sure to connect them to the correct terminals. Refer to Figure 45, and the Power Distribution Diagram on page 79.

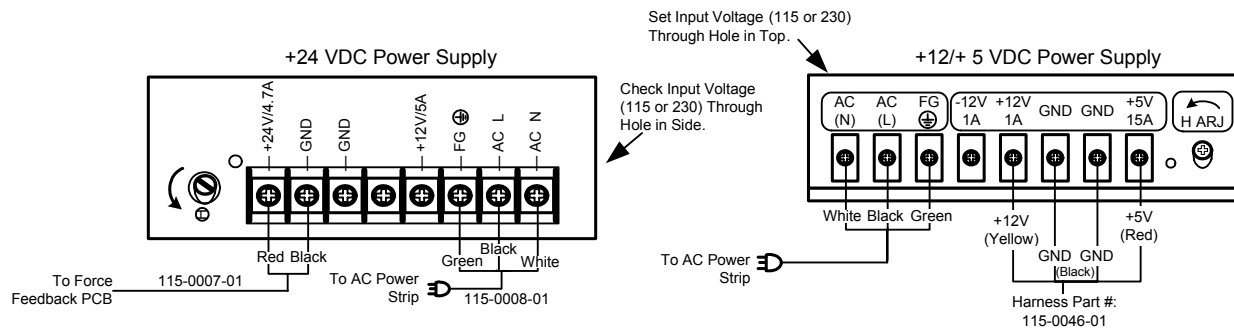

Figure 45. DC Power Supply Connections

## Cabinet Lighting Service

The cabinet lighting consists of a florescent fixture behind the marquee artwork, a light bulb behind the LEADER artwork, and three pairs of cold cathode florescent lights. The figure below shows the type and location of each light:



Figure 46. Cabinet Lighting Locations

## Marquee Florescent Light Service

The Marquee is lighted by one florescent fixture. To gain access to the fixture, remove the eight (8) Torx screws that secure the marquee artwork and clear plastic in place.

Replace the florescent tube with another 18" florescent tube.

To remove the fixture, disconnect the cabinet from AC power. Disconnect the AC power cord from the fixture. Remove the two Phillips screws that secure the fixture to the cabinet and remove the fixture.

Replace the fixture with part # 49-1001-00.

## Leader Light Service

The leader light uses a mini 12V bayonet-base bulb. To replace the bulb in the leader light, remove the four (4) Torx screws that secure the LEADER artwork in place and remove the artwork. Carefully push the bulb inward and rotate counterclockwise 1/4 turn to remove.

To install a new bulb, align the bulb with the socket, push inward, and rotate clockwise 1/4 turn. Re-install the artwork with the four screws removed previously.

## Brake Light Replacement

The brake light (tail light) assembly is a 12-inch blue LED array that is secured inside the pedestal with two screw-mounted cable ties. The LED array connects directly to the power harness and does not use a power inverter.

1. To replace the brake light, remove the four Torx screws that secure the clear plastic panel under the cold-cathode light at the rear of the pedestal.
2. Remove the clear plastic panel with the cold cathode light attached, and reach inside the pedestal to access the brake light.
3. Disconnect the LED array from the power harness.
4. Unscrew the cable ties and remove the LED array.
5. Reverse these steps to install a new LED array.

### Cold-Cathode Light Service

The cabinet uses three pairs of cold-cathode lights. Each pair of lights is connected to a power inverter that receives +12 VDC from the +5/+12 VDC power supply. Cold-cathode lights have an average lifespan of 30,000 hours.

Refer to Figure 46 on the previous page for cold cathode light locations. The table below describes how to replace each light and the location of the power inverters. Refer to Figure 47 on page 79 for a diagram of the cold cathode assembly.

If both lights in a pair go out at the same time, check the connections between the DC power supply and the power inverter. If one light goes out, check the connection between the light and the power inverter.

The following table describes how to access the lights at each location in the cabinet. Power inverters are secured to the cabinet with Velcro®.

Location	Procedure
Behind Artwork to Right of Monitor	Remove the four (4) Torx screws that secure the plastic panel and artwork to the cabinet. Each of the two lights is secured to the cabinet with two screw-mounted cable ties. The power inverter is located in the back of the cabinet behind the location of the lights.
Driving Control Panel Artwork	Open the driving control panel as described on page 79. The light is secured to the cabinet with two screw-mounted cable ties. The power inverter is located inside the control panel.
Pedals	Remove the four (4) Torx screws that secure the clear plastic panel above the pedals. The light is secured to the panel with two cable ties. The power inverter is located inside the control panel.
Back of Seat	Remove the four (4) Torx screws that secure the clear plastic panel under the light. The light is secured to the panel with two cable ties. To access the power inverter, remove the four bolts that secure the seat assembly to the cabinet, slide the assembly away from the cabinet, and turn the seat assembly on its side.
Under Seat Assembly	Remove the four (4) bolts that secure the seat assembly to the cabinet and slide the assembly away from the cabinet. Turn the seat assembly on its side to access the light and the power inverter.

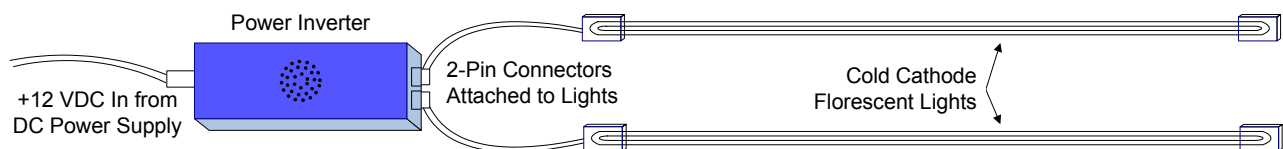

Figure 47. Cold Cathode Florescent Light Wiring

## Setting the Computer BIOS (CMOS)

**Important:** Your screens may not look exactly like the screens shown below, and some settings shown on the screens below may be different from your system. **Do not change any settings that are not specifically described in this document.**

1. Press the **DEL** key during boot. The CMOS Setup Utility Main Menu will appear:

2. Use the Arrow keys (**↑↓→←**) to select **Load Optimized Defaults**, and press **Enter**.

Press **Y** and **Enter** when prompted to confirm the change.

**Note:** Step 2 ensures that most settings are correct. The others are described in this document.

3. Use the Arrow keys to highlight **Standard CMOS Features**, and then press **Enter**.

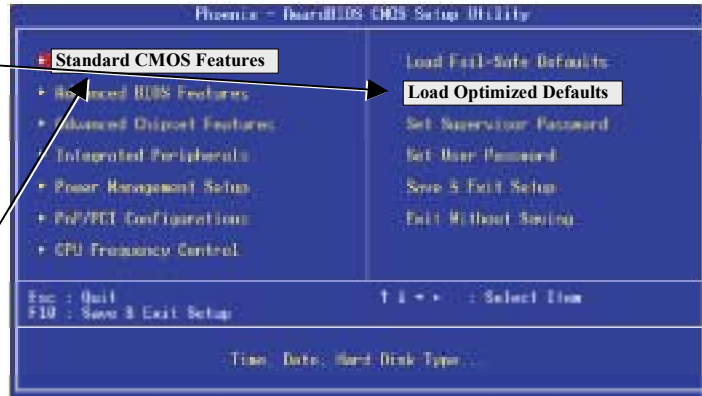

A screen similar to the following will appear:

4. Use the Arrow keys to highlight the setting for **Halt On**. Use the **Page Up** and **Page Down** keys to change the setting to **No Errors**.

Press **ESC** to go back to the Main Menu.

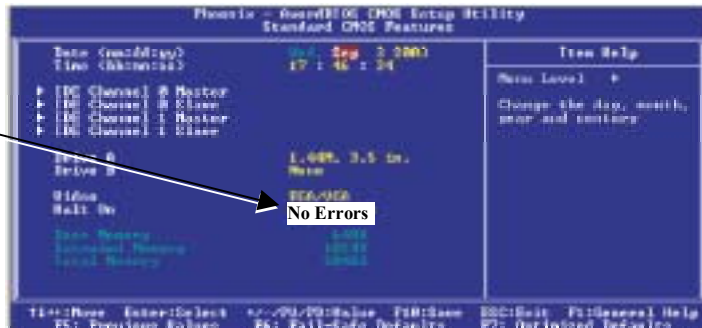

5. Now use the Arrow keys to highlight **Advanced BIOS Features** and press **Enter**. A screen similar to the following will appear:

6. Use the Arrow keys to highlight the setting for **First Boot Device**. Use the **Page Up** and **Page Down** keys to change the setting to **CDROM**.

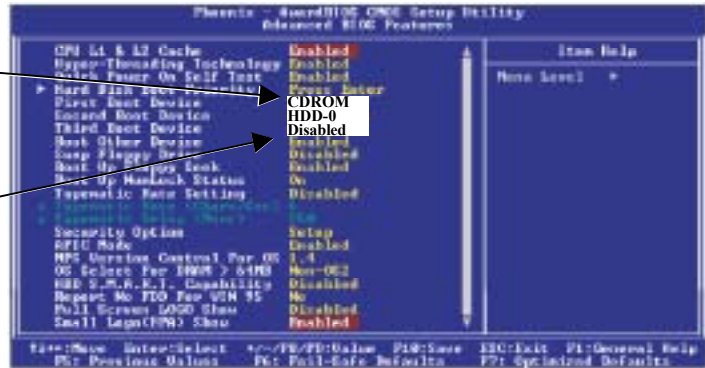

7. Set **Second Boot Device** to **HDD-0** and **Third Boot Device** to **Disabled** the same way. Press **ESC** to go back to the Main Menu.

8. Now use the Arrow keys to highlight **Advanced Chipset Features** and press **Enter**. A screen similar to the following will appear:

9. Use the Arrow keys to highlight the setting for **Memory Frequency For**. Use the **Page Up** and **Page Down** keys to change the setting to **DDR266**.

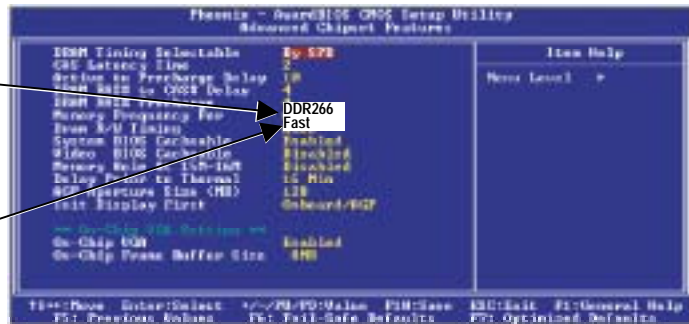

10. Use the Arrow keys to highlight the setting for **Dram R/W Timing**. Use the **Page Up** and **Page Down** keys to change the setting to **Fast**.

11. Now use the Arrow keys to highlight **Power Management Setup** and press **Enter**. A screen similar to the following will appear:

12. Use the Arrow keys to highlight the setting for **PWR Loss Resume State**. Use the **Page Up** and **Page Down** keys to change the setting to **Turn On**.

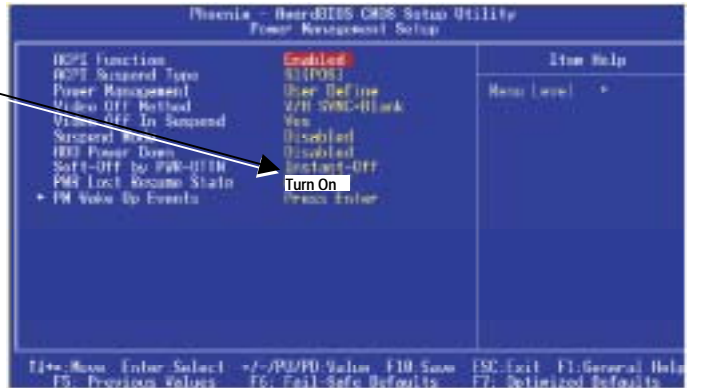

13. Now that all settings are correct, press **F10**. The following prompt will appear:

Save to CMOS and EXIT (Y/N) Y

14. Make sure "Y" shows at the end of the prompt (if "N" shows, the settings will not be saved), and press **Enter** to save the settings and exit.

## Chapter 8 — Troubleshooting

### Video Troubleshooting

Problem	Cause	Possible Solution
No picture on monitor	Power problem	Verify the AC power connection to the monitor. You can verify that the monitor has power by looking for a small glow in the neck of the CRT.
	Loose or faulty video cable	Verify that the video cable is firmly connected from the monitor to the video card on the computer. While the monitor is powered ON, disconnect the video cable. You should see a message on-screen saying <i>No Signal</i> to verify the monitor is working. Check the video cable and make sure it is not pinched or frayed.
	Loose or faulty video card	When the computer boots up, it performs a PC self-diagnostic test. If you hear 3 beeps from the computer, this indicates a problem with the video card. If the video card is faulty, contact Technical Support.
	Faulty monitor chassis PCB	Verify that the fuses on the monitor chassis PCB are good and that all connections are firm.
Picture is dim or faded	Gamma needs adjustment	Use the monitor remote control board to adjust the brightness and contrast settings. Adjust the monitor gamma setting from the Operator Menu to increase overall brightness (see page 79).
Color is poor	Color needs adjustment	Use the monitor remote control board to adjust the red, green, and blue color settings.
Picture is misaligned	Geometry needs adjustment	Use the monitor remote control board to adjust the picture height and width as well as other geometric adjustments.
No video and no audio  (Note: It may take nearly 2-1/2 minutes to boot and start the game.)	No power to computer	Verify the computer is ON by the green LED on the front of the computer. Verify the line voltage switch on the back of the computer is set to the correct voltage for your area: 115V or 230V. Make sure the AC power cord is firmly connected to the computer and the power strip. Turn off the power strip, wait 20 seconds, and then turn it back on to reboot the computer.
	Corrupted software	Reload the software from the System Restore CDs. If you continue to have problems after you reload the software, you may have a faulty hard drive.
	Faulty hard drive	If you continue to have problems after you reload the software, you may have a faulty hard drive. Contact Technical Support.
Poor picture	Monitor connected to wrong port	The monitor must be connected to the VGA Video port on the video card, <b>not</b> to the video port in the computer motherboard. Make sure that the monitor video cable is connected to the VGA Video port located below the audio connectors (see Figure 59 on page 79).

### Audio Troubleshooting

Problem	Cause	Possible Solution
No audio	Volume set too low	Enter the Operator Menu and adjust Audio Settings to raise the volume. Verify that the Master Volume is set high enough. Verify the volume is not turned all the way down at the Audio Amp PCB (see Figure 39 on page 79).
	Faulty wiring	Turn off the game. Verify that all the wires are firmly connected to the speakers and Audio Amp PCB. Verify that each wire is connected to the correct port. Verify that no wires are frayed or improperly shorting to ground. (See Figure 55 on page 79 for audio wiring).
	Blown speakers	Remove the grills and inspect each speaker for visible damage. Run the Speakers Test from the Operator Menu to verify each speaker is working.
	Faulty audio amp PCB	You can verify the Audio Amp PCB is working by installing it into another working cabinet. If that is unavailable to you, plug a simple computer speaker into the audio ports on the computer and verify that sound is working at the computer.
Poor sound from one or more speakers	Blown speakers	Remove the grills and inspect each speaker for visible damage. Run the Speakers Test from the Operator Menu to verify each speaker is working.
	Reversed wires	A weak or low muffled sound is a sign of reversed speaker wires. Check for reversed wires on each speaker. (See Figure 55 on page 79 for audio wiring).
	Faulty audio amp PCB	You can verify the Audio Amp PCB is working by installing it into another working cabinet. If that is unavailable to you, plug a simple computer speaker into the audio ports on the computer and verify that sound is working at the computer.
	Faulty wiring	Verify that all the wires are firmly connected to each speaker and the Audio Amp PCB. Verify that no wires are frayed or improperly shorting to ground.
Audio hum	Faulty power supply	A constant low hum in the speakers can be caused by a faulty power supply.

### Control Troubleshooting

Problem	Cause	Possible Solution
Buttons do not work	Faulty micro switch	Replace the micro switch on the button and re-test. Verify that the wires are connected to the correct spades on the micro switch.
	Faulty wiring	Disconnect the cabinet from AC power. Verify that all wires are firmly connected to each button and the USB I/O Extreme PCB. Verify that no wires are frayed or improperly shorting to ground.

Problem	Cause	Possible Solution
	Faulty USB I/O PCB	Make sure that all connections to the PCB are firm. Replace PCB if faulty.
Steering pulls to one side	Faulty force-feedback PCB	Verify that the force-feedback PCBs are getting 24 volts DC power. Test the PCBs in a working cabinet.
	Faulty force-feedback motor	Test the motor in a working cabinet.
	Faulty force-feedback power supply	Use a volt meter to verify that the force-feedback power supply is putting out 24 volts DC.
Sloppy or poor steering	Poor calibration	Calibrate the steering from the Play Control Test in the Operator Menu.
	Faulty 5 K $\Omega$ steering pot	Test the steering calibration from the Play Control Test in the Operator Menu. Replace pot if faulty (see page 79).
	Loose or worn drive belt	Turn off the cabinet. Open the driving control panel and check the belt on the force-feedback motor and steering column. Check for loose or worn parts on the force-feedback assembly (see page 79).
	Faulty force-feedback PCB	Verify that the PCBs are getting 24 volts DC power. Verify the 7.5-amp fuse on the back of the power PCB is not blown. Test the PCBs on a working cabinet. Calibrate the steering from the Play Control Test in the Operator Menu.
No force-feedback in the steering wheel	Faulty force-feedback motor	Test the motor in a working cabinet.
	Faulty force-feedback power supply	Use a voltmeter to verify that the force-feedback power supply is putting out 24 volts DC.
	Force-feedback motor not properly grounded	Make sure the force-feedback motor frame is properly grounded. Static shock can stop the steering wheel from responding during game play. Power the cabinet Off and then ON to correct this problem.
	Faulty force-feedback PCB	Verify that the PCBs are getting 24 volts DC power. Verify the 7.5-amp fuse on the back of the power PCB is not blown. Test the PCBs on a working cabinet.
	Force-feedback connected to wrong USB port	The force-feedback card must be connected to a PCI USB port, <b>not</b> to a motherboard USB port. See Figure 59 on page 79 for a diagram of the computer ports.
Steering does not auto-calibrate	Faulty USB cable or PCI USB card	Test by connecting to one of the USB ports on the computer motherboard and rebooting twice. Re-connect to the PCI USB port and reboot after testing to avoid intermittent steering loss during game play.
	Faulty force-feedback PCBs	Verify that the PCBs are getting 24 volts DC power. Verify the 7.5-amp fuse on the back of the power PCB is not blown. Test the PCBs on a working cabinet.

Problem	Cause	Possible Solution
Steering wheel shakes	Faulty 5 K $\Omega$ steering pot	Test pot for smooth resistance. If you replace the pot, be sure to calibrate it from the Play Control Test in the Operator Menu.
Steering stops working (Intermittent)	USB cable in wrong port	The USB cable must be connected to the PCI USB port, <b>not</b> the USB port on the computer motherboard (see Figure 59 on page 79).
Shifter does not work in some gears	Faulty micro switch or switches	Replace the faulty micro switch. See the Play Controls screen in the Operator menu, or page 79 of this manual to determine which micro switch to replace.
Shifter does not work	Faulty USB I/O PCB	Make sure that all connections to the PCB are firm. Replace PCB if faulty.
Gas and brake do not work properly	Pedals out of calibration	Calibrate the pedals from the Play Control Test in the Operator Menu. If you replace a pot or the computer, always recalibrate the pedals. (Pedals <b>do not</b> auto-calibrate when you reboot the game.)
	Faulty 5 K $\Omega$ pot	Test pot for smooth resistance. If you replace the pot, be sure to calibrate it from the Play Control Test in the Operator Menu.

### Cabinet Linking Troubleshooting

Problem	Cause	Possible Solution
Cabinet will not connect	Faulty wiring	Verify that an Ethernet cable is connected between the Ethernet port on the AC power plate and the computer. While the cabinet is powered on and connected to another cabinet, verify the green LED on the Ethernet card is lit to verify a good hardware connection. If you are using an Ethernet hub, verify the LEDs light for each Ethernet port used.
	Wrong hardware being used	A crossover coupler can only be used to link two cabinets. When linking 3 or more cabinets, use a hub.
Cabinet does not link in software	Duplicate linking ID numbers	If you get a duplicate Link ID number error on-screen, go into the Operator menu and correct the Link ID number for each cabinet that displays the error message. Each cabinet in the networked group must have a unique link ID number.
	Faulty wiring	Verify that an Ethernet cable is connected between the Ethernet port on the AC power plate and the computer. While the cabinet is powered on and connected to another cabinet, verify the green LED on the Ethernet card is lit to verify a good hardware connection. If you are using an Ethernet hub, verify the LEDs light for each Ethernet port used.
	No cross-over coupler	To connect two cabinets, you must use one cross-over coupler (or hub). Do not run an Ethernet cable between two cabinets without a coupler.
	Faulty Ethernet hub	Verify the LEDs on the Ethernet hub are lit for each port used. If possible, verify the Ethernet hub is working by connecting it to a known working computer network or set of linked cabinets.

Problem	Cause	Possible Solution
	Mixed software version	Verify that all cabinets are running the same software version.
	System needs reboot	For linked cabinets to recognize each other, it is very important to reboot all cabinets in the group when adding or removing linked cabinets, or changing the cabinet link ID numbers.

### Miscellaneous Troubleshooting

Problem	Cause	Possible Solution
No power	Power strip not plugged in or turned off	Make sure the power indicator light on the power strip is on. If it is off, make sure the connections to the AC power plate terminals are firm and the power strip ON/OFF switch is ON.
	Cabinet not connected or turned off	Make sure the AC power cord is firmly connected to the power plate and an active AC outlet, and the cabinet ON/OFF switch is ON.
Game dongle not found by system computer <b>(Important:</b> If a USB dongle is used, it must be connected through a PCI USB port, not a motherboard USB port.)	Game dongle not connected	Make sure the game dongle is securely connected. Power the cabinet off and then on.
	Faulty game dongle	Make sure the dongle is connected properly. (USB dongles illuminate when recognized by the computer. Parallel dongles do not.) Contact Tech Support if you need to order a new dongle.
	Faulty USB or parallel port	If you try a different game dongle and reboot the game, but the dongle still is not recognized, contact Tech Support.
Cabinet gets very warm	Faulty ventilation fan	Verify that the exhaust fan is working. It is located under the vents at the top of the cabinet. Replace the fan if it is worn or spinning slowly.
	Cabinet ventilation holes are blocked	Make sure you have proper clearance between the cabinet rear and the wall. Make sure the vent holes are clear of dust and debris and that air can flow freely.
Marquee lamp does not light or is intermittent	Faulty florescent tube	Check the florescent tube for darkened or cracked end. Replace the florescent tube if it looks worn.
	Faulty florescent fixture	Verify the florescent tube pins make a good connection with the lamp fixture. Check the ballast for proper operation. Replace fixture if faulty.
Improper number of credits given when coins or bills are inserted	Incorrect setting in Operator Menu	Adjust settings from the Operator Menu.
	Faulty wiring	Disconnect the cabinet from AC power. Verify that all wires are firmly connected to the coin mech and bill validator. Verify that no wires are frayed or improperly shorting to ground.
	Faulty coin mech	Repair or replace the coin mech.
	Faulty bill validator	Repair or replace the bill validator.

Game will not accept coins or bills	Faulty coin mech	Verify the coin mech is not jammed. Make sure the coin mech is properly aligned and latched to the coin door.
	Faulty bill validator	Verify the bill validator is powered on and working. If the bill validator is faulty it will usually blink an error code on the inside of the coin door.
Bill validator rejects too many bills	Poor ground	Verify the cabinet is properly grounded and the bill validator is properly connected to ground.

## Connection Troubleshooting

If the cabinet fails to connect with the Tournament Server due to a problem with the dial-up modem or the broadband connection, the cabinet will display an error message onscreen. The table below lists the more common errors and solutions.

If you cannot resolve a connection problem, contact Technical Support. Please have the modem error code, dial-up phone number the computer is using, and the game serial number ready for the GLOBAL VR<sup>®</sup> technical support representative.

Modem Error Message	Cause	Possible Solution
General RAS Failure	Modem failed to connect	Make sure you have a working analog phone line connected to the LINE port on the modem. If the problem continues, select a different phone number in the dial-up settings.
No Dial Tone – Please try again	Phone line connected to wrong modem port	If you can hear the phone go off the hook, make sure the phone line is connected to the correct port on the modem (see Figure 59 on page 79).
	Phone line not working	Connect a telephone to the line to make sure it is working.
The line is busy – Please check phone line and try again	Phone line is busy	Try again later. If the problem persists, select a different dial-up number.
Failed to deserialize – Please contact GlobalVR Support	Problem syncing with server	Contact GLOBAL VR <sup>®</sup> Technical Support
Broadband Error Messages		
Error Communicating with Server. Please try again later (4001)	Broadband connection problem	Check all connections and make sure your network is functioning properly.

## External Monitor Troubleshooting

Refer to the following information if you have problems using an external monitor to display the cabinet video outside of the cabinet. The exact appearance of the dialog boxes and settings will vary depending on the video card installed in your computer.

1. Power the cabinet OFF and connect the PS/2 keyboard to the purple PS/2 port on the back of the computer. Turn the cabinet power ON, and let the game boot up.
2. With the game running in Attract mode, press the Windows flag key  on the keyboard (between the *Ctrl* and *Alt* keys). This will launch the Windows Start Menu.

- Use the arrow keys to select **GVR Shutdown** and press **Enter**. This will shut down the game shell and allow you to access Windows features.
- Use the arrow keys to select **Display Properties**, and press **Enter**. This will launch the Display Properties Window.
- Use the arrow keys to select the **Settings** tab.

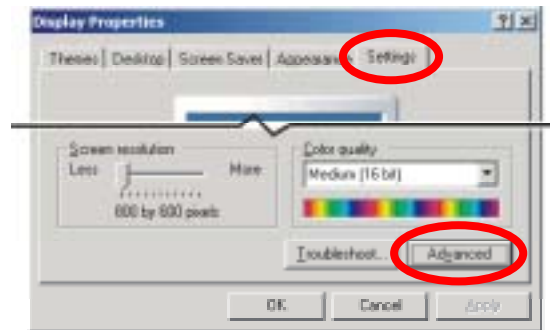

Figure 48. Selecting the Settings Tab in the Display Control Panel

- Use the **Tab** key select the **Advanced** button, and press **Enter**. The monitor and video card properties window will be displayed:

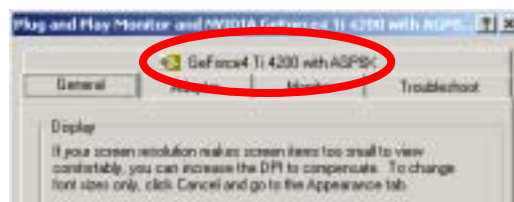

Figure 49. Selecting the Video Card Name Tab

- Use the **Tab** and arrow keys to move to the **GeForce4** tab. (The exact name of the video card will vary depending on the video card installed). A window like the following will be displayed:

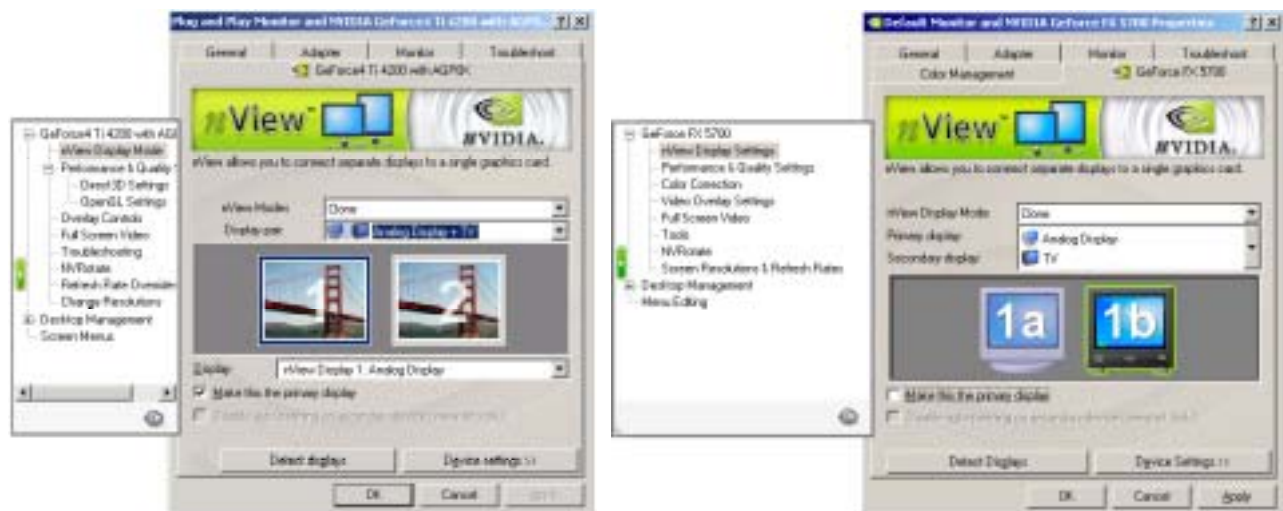

Figure 50. Choosing a Display Pair with Cloning

- Use the **Tab** and cursor keys to select **nView Display Mode** in the menu at the left. Change the **nView Modes** option to "**Clone**", and the **Display pair:** option to "**Analog Display + TV**".

If the screen has two lines in the field below nView Modes, set **Primary display:** to **Analog Display** and **Secondary display:** to **TV**.

9. Select the image of the TV in the graphic below the nView Display Mode fields and then press **Tab** to select **Device Settings >>**. Press **Enter**.
10. Press the down arrow to select **TV format** in the context menu that appears.
11. In the second context menu, select **Advanced**.
12. Select either **Composite Video Out** or **S-Video Out** from the **Video Output format** dropdown menu.
13. After making these changes, select **OK** in the monitor and video card properties window, and then press **Enter**.

You should now see the video image displayed on both the internal and external monitor. You will also see the following dialog box displayed:

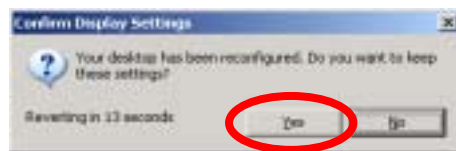

*Figure 51. Confirming Display Settings*

14. If everything looks correct, press the **Tab** key to select **Yes**, and then press **Enter**. This will save the settings.
15. If you do not see the image in the external monitor, check the S-Video cable, and check that the external monitor is set to receive video from the S-Video input.
16. When you finish changing display settings, power the cabinet OFF, and disconnect the keyboard from the computer.

## Chapter 9 — Replacement Parts

If you need replacement parts, refer to the part numbers listed below when you contact your distributor or GLOBAL VR® Technical Support.

**Note:** "Qty" column refers to total quantity of a part used on a cabinet.

### Documents and Software

Part #	Qty	Description
040-0049-01	1	System Manual
040-0069-01	1	Software Restore Guide
050-0070-01	1	System Recovery Disk
050-0071-01	1	Game Install Disks (2)

### Cables

Part Number	Qty	Description
115-0005-01	1	Cable, Steering Pot to Force Feedback
115-0006-01	1	Cable, Steering Motor to Force Feedback
115-0007-01	1	Cable, +24VDC to Force Feedback
115-0008-01	2	Cable, 110VAC to +24VDC Power Supply
115-0010-01	1	Cable, 110VAC to Florescent Fixture
115-0011-01	1	Cable, Audio Amp to Seat
115-0012-01	1	Cable, Audio Amp to Marquee
115-0013-01	1	Cable, Ground to Coin, Pedal, Steering
115-0065-01	1	Cable, Front Speakers, Leader Light, Florescent Light
115-0066-01	1	Cable, Seat Speakers
115-0067-01	2	Cable, Control Panel Button Harness
115-0068-01	1	Cable, DB25 to Buttons & Leader Light
115-0069-01	1	Cable, DB37 to Lamps, Coin, Shifter
115-0070-01	1	Cable, 12V/5V DC Power Harness
115-0071-01	1	Cable, Seat, Shifter, Brake Light, CCFL

### Control Panel

Part Number	Qty	Description
SCR28I-S033U	1	SmartCard Reader
26066-00	2	ESD Isolation Block for SmartCard Reader
50-0102-14	1	Steering Assembly (Wheel, Motor, and Cover Plate)
59-6004-800H1628	1	START Button Assembly
59-6004-810H1933	2	NOS Button Assembly
59-6004-855H1625	1	VIEW Button Assembly
59-6004-855H1626	1	MUSIC Button Assembly
59-6004-855H1648	1	LOOK BACK Button Assembly
50-0413-00	1	Dual Pedal Assembly (Gas and Brake) (See page 79 for pedal assembly parts)
50-2670-00	1	Steering Pot (Potentiometer), 5 K $\Omega$
50-8026-00	2	Gas or Brake Pot (Potentiometer), 5 K $\Omega$

## Cabinet and Marquee

Part Number	Qty	Description
26001-00	1	Marquee Housing
26015-00	1	Clear Plastic Panel for Marquee Artwork
26020-00	1	Clear Plastic Panel for Leader Light
37032-00	2	Speaker Grill, Marquee
01-0045-LBH	1	Speaker Grill, 4", Center Speaker
24-8870	1	Leader Light Socket
CCFL1B1W	1	Cold Cathode Florescent Light Kit Dual 12", White & Blue (Control Panel)
CCFL2W	1	Cold Cathode Florescent Light Kit Dual 12", White (Bezel)
37039-00	1	Leader Light Plate
91-1129-00	1	Lamp, Mini 12V, Bayonet-Base (Leader Light)
49-1001-00	1	Florescent Light, 18"
5555-15098-00	2	Speaker, 8 Ohm, Shielded, 5-1/2"
1123LBT	1	Cabinet Fan, 115V AC/11 Watts 120 sq mm x 38 mm
26006-00	1	Floor Mat
26014-00	1	Clear Plastic Panel, Control Panel, Dashboard Instruments
40-3000-31	1	Coin Door Assembly O/I Mid-width .25 US, OP Switch, W/O AMP
42-8040-00 GVR	1	Coin Vault
44-0600	1	Power Supply +24 VDC
44-1100-01	1	Power Supply, +5/+12 VDC, 115 W
45007-00		Power Plate Assembly
115-0049-01	1	Ground Cable, 3.5" (Power Plate)
283-2025-ND	1	Fuse, SLO BLOW, 250V / 6 AMP (Power Plate)
ECF504-4C	2	RJ11 Coupler (6X4), Crossed, 30u (Power Plate)
ECF504-8SK	1	RJ 45 Coupler (8X8), Straight, 30u (Power Plate)
TDC053-7	1	RJ45 Modular Cable (8X8), 7' Straight (PC to Power Plate)
TDC207	1	Modular Cable, RJ-11 Plug to Plug, Crossed Wiring (Power Plate)
WGM2792-UOTS53D	1	Monitor, Wells-Gardner®, 27", Flat-Screen

## Computer

Part Number	Qty	Description
45035-00	1	System Computer Assembly
08324	1	PCI USB Card, 4-Ports
315-0512-40	1	DDR RAM, 512MB, PC2700-32x8
4300-0004	1	Modem, PCI, Creative Lab Blaster 56K, V.90
4300-0005	1	Motherboard, PS35-BL (ACP)
CDR-SN5221	1	CD-ROM Drive, Sony, 52x IDE
CPU-2400	1	CPU, P4, 2.4Ghz 256k FSB-533, w/ Heat-Sink & Fan
GF6600-8XAGP-256MB	1	Video Card, GF6600, 256MB
HD-WD200BB	1	HD IDE ATA 100 7200RPM Western Digital, 20GB
G80-00005	1	License, Microsoft® Windows® XP Embedded

Part Number	Qty	Description
USBIOEXT	1	USB/I/O Extreme PCB
PS2-KEYBOARD	1	PS2 Keyboard
USB-AB06MM	2	USB-2 Cable, 6'
USB-KQRTG	1	Game Dongle, USB

### Steering and Audio PCB Assembly

Part Number	Qty	Description
49-1019-00	3	PCB Mounting Feet, Set of 4
990-0001-01	1	5.1 Audio Amp PCB
COEM-6052*	1	Force-Feedback Motor Controller PCB (green board)
COEM-6040-245*	1	Force-Feedback PCB (blue board)
SP-610*	1	Cable, Force-Feedback PCB Interconnect

\*COEM-6052, COEM-6040-245, and SP-610 can all be replaced by COEM-ELEC-AW-SB-GVR.

### Seat Assembly

Part Number	Qty	Description
50-0414-30	1	Six-Speed Shifter Assembly (See page 79 for shifter assembly parts.)
54-0006-200H1985	1	E-Brake Button Assembly
50-0400-00	1	Seat Slide Assembly
26017-00	1	Clear Plastic Panel, Pedestal Base
26018-00	1	Clear Plastic Panel, Brake Light
26019-00	1	Clear Plastic Panel, Pedestal Rear
METL12BU	1	Tail Light Assembly, 12" Blue Led Array
49-0963-40	1	7-Outlet Surge Protector/Power Strip, 6'
52-6212-00	1	Button Plugs (Black)
5555-15098-00	1	Speaker, 8 Ohm, Shielded, 5-1/2"
96-0539-00	3	Cable, Stereo, 3.5 MM, 6'
A-1 VENTILATOR	1	SM, 4" x 13" Cabinet Ventilator
CAT5-AD125-00	1	RJ45 Crossover Coupler
CCFL2BU	1	Cold Cathode Florescent Light Kit Dual 12", Blue

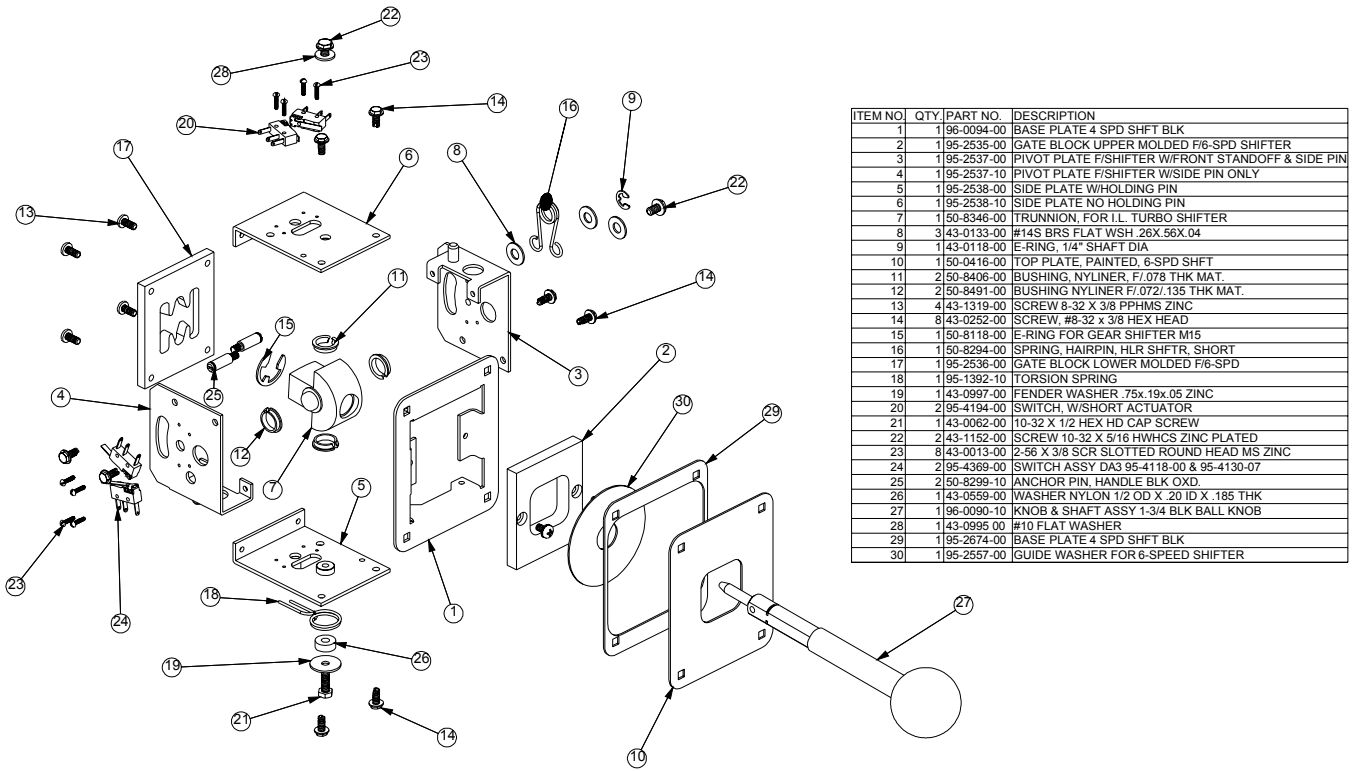

Figure 52. Six-Speed Shifter Exploded View and Parts

ITEM NO.	QTY.	PART NO.	DESCRIPTION
1	1	95-2534-00	PEDAL & BEAM ASSY PERFORATED BREAK CHROME
2	1	95-2520-00	PEDAL & BEAM ASSY PERFORATED GAS CHROME
3	1	50-8372-90	PEDAL FRONT PLATE DUAL SMOOTH BLACK
4	4	50-2598-00	SIDE PLATE RIGHT & LEFT
5	4	50-8171-00	BUMPER
6	8	50-8170-00	SPACER, TUBE
7	1	50-8042-00	SPRING F/PEDAL, RH HELIX
8	2	50-8049-00	SPRING F/PEDAL, LH HELIX
9	2	50-2979-00	PIVOT SHAFT, PAINTLOC
10	2	50-8069-02	GEAR, 1MOD, 12T, .25 BORE
11	2	96-4916-00	LONG LIFE POT W/NUT & WSHR 5K
12	2	95-0925-00	GEAR SEG 1MOD 80T
13	8	43-0726-00	CARRIAGE BOLT, 1/4-20 X .50 BLK OXD.
14	9	43-0075-00	SCREW, M5 X 60MM HHCS
15	2	43-0269-00	SCREW, M6 X 30MM HHCS
16	9	43-0068-00	LOCKWASHER, M5 RIBBED
17	8	90-1209-00	1/4-20 HEX NUT W/KEPS
18	2	43-0983-00	LOCKWASHER M6 RIBBED
19	2	43-0050-00	HEX NUT M4
20	2	43-0051-00	SCREW, M4 X 16 MM HHCS
21	4	43-0198-00	WASHER, M4 FLAT WSH DIN 125A
22	2	43-0277-00	SET SCREW, M4X8MM CUP POINT
23	9	43-0125-00	NUT M5
24	4	50-2587-00	BUSHING, .35 DIA 5/16 O.D.
25	2	50-0097-00	WASHER GUIDE 4.38 X 1.75 W/.44 SQ HL BLK PLST
26	1	50-0008-00	COMPRESSION SPRING, .94 OD X 2.00 LG X .125 DIA W.
27	1	50-0011-00	CYLINDER & TUBE ASSY, I.T. PEDAL

Drawing © Happ Controls

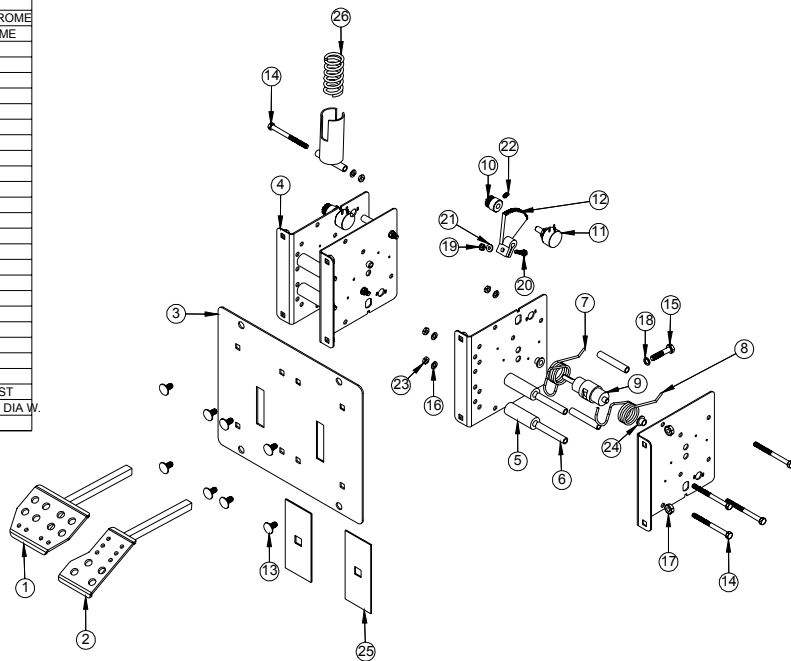
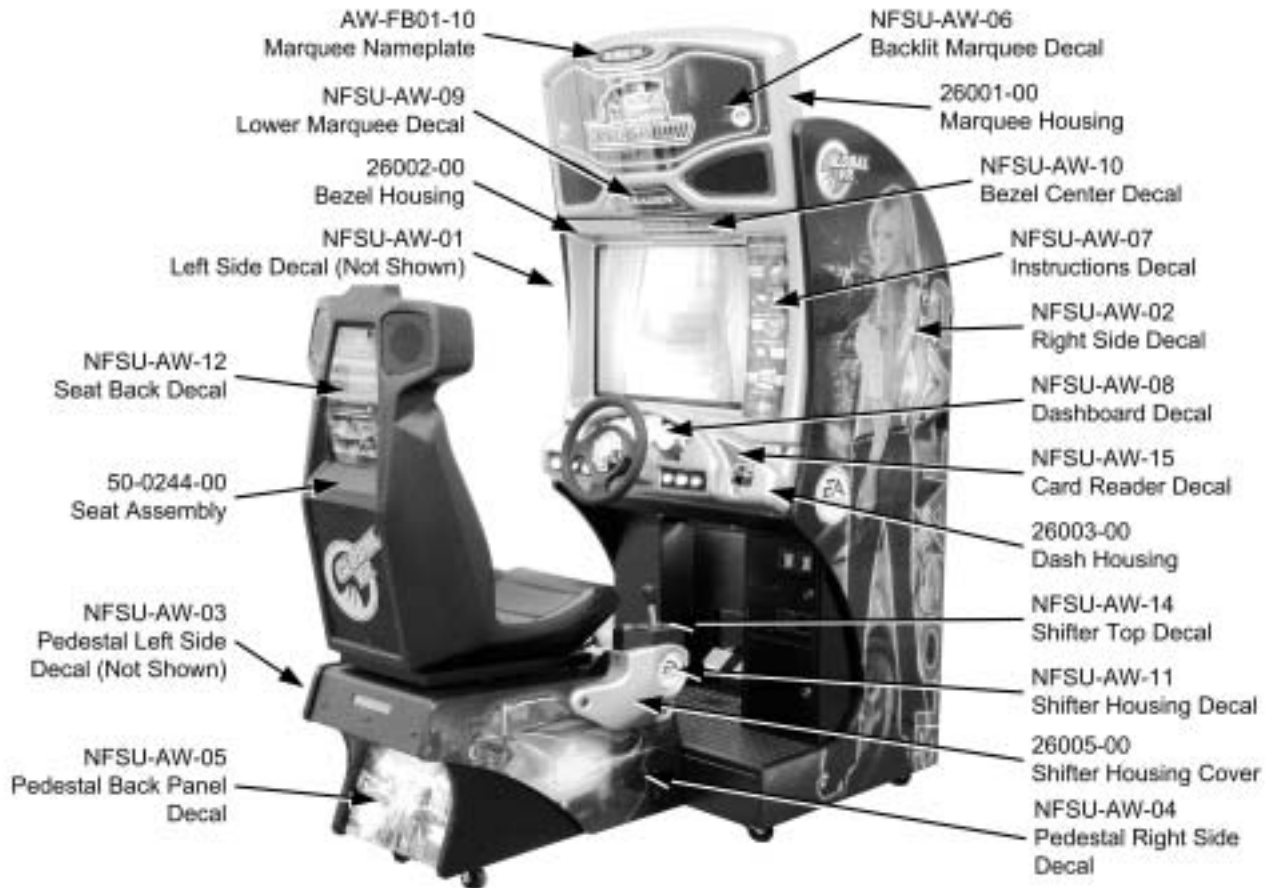

Figure 53. Pedal Assembly Exploded View and Parts

## Artwork and Formed Plastic Components



*Figure 54. Artwork and Formed Plastic Part Numbers and Locations*

# Chapter 10 — Diagrams and Schematics

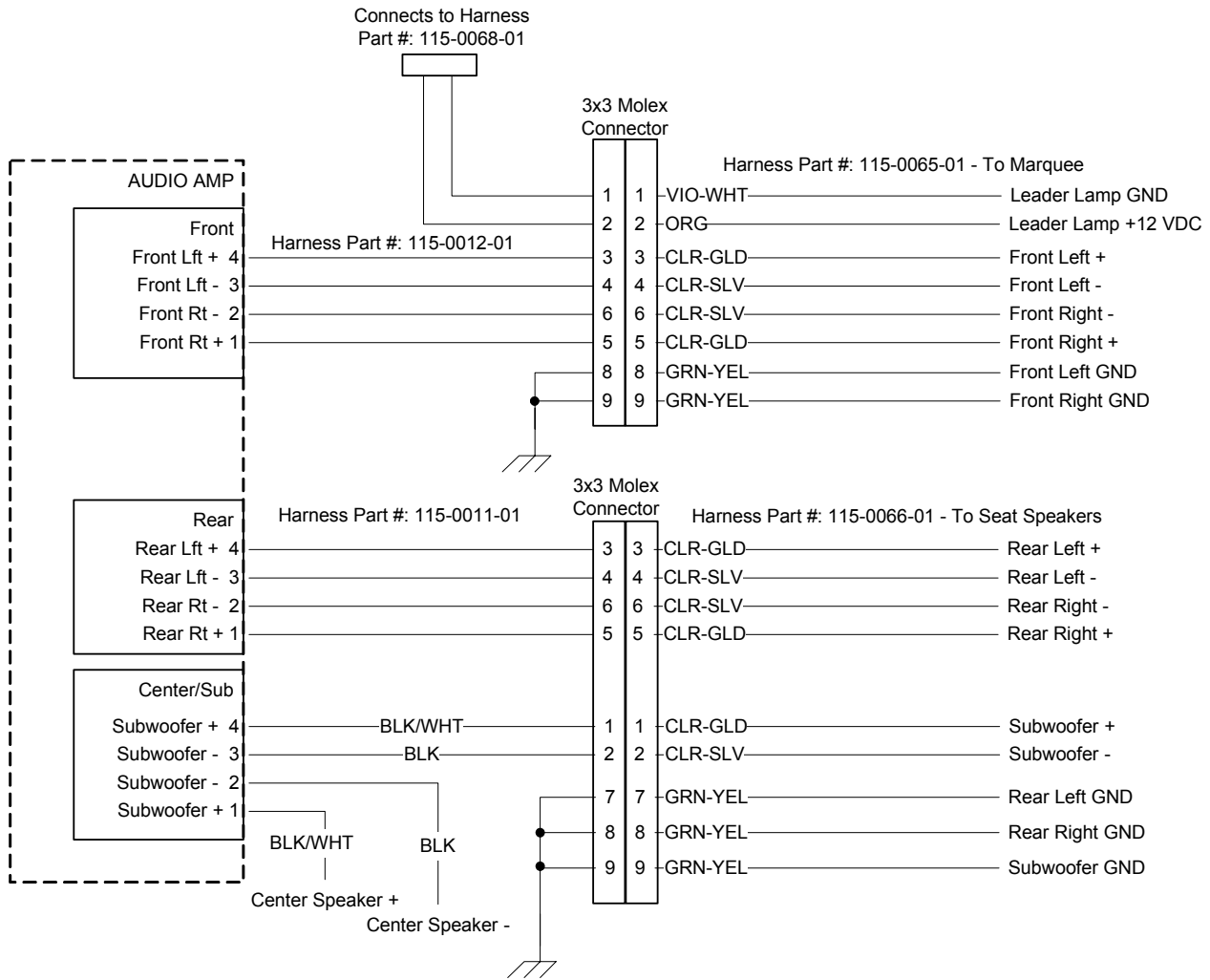
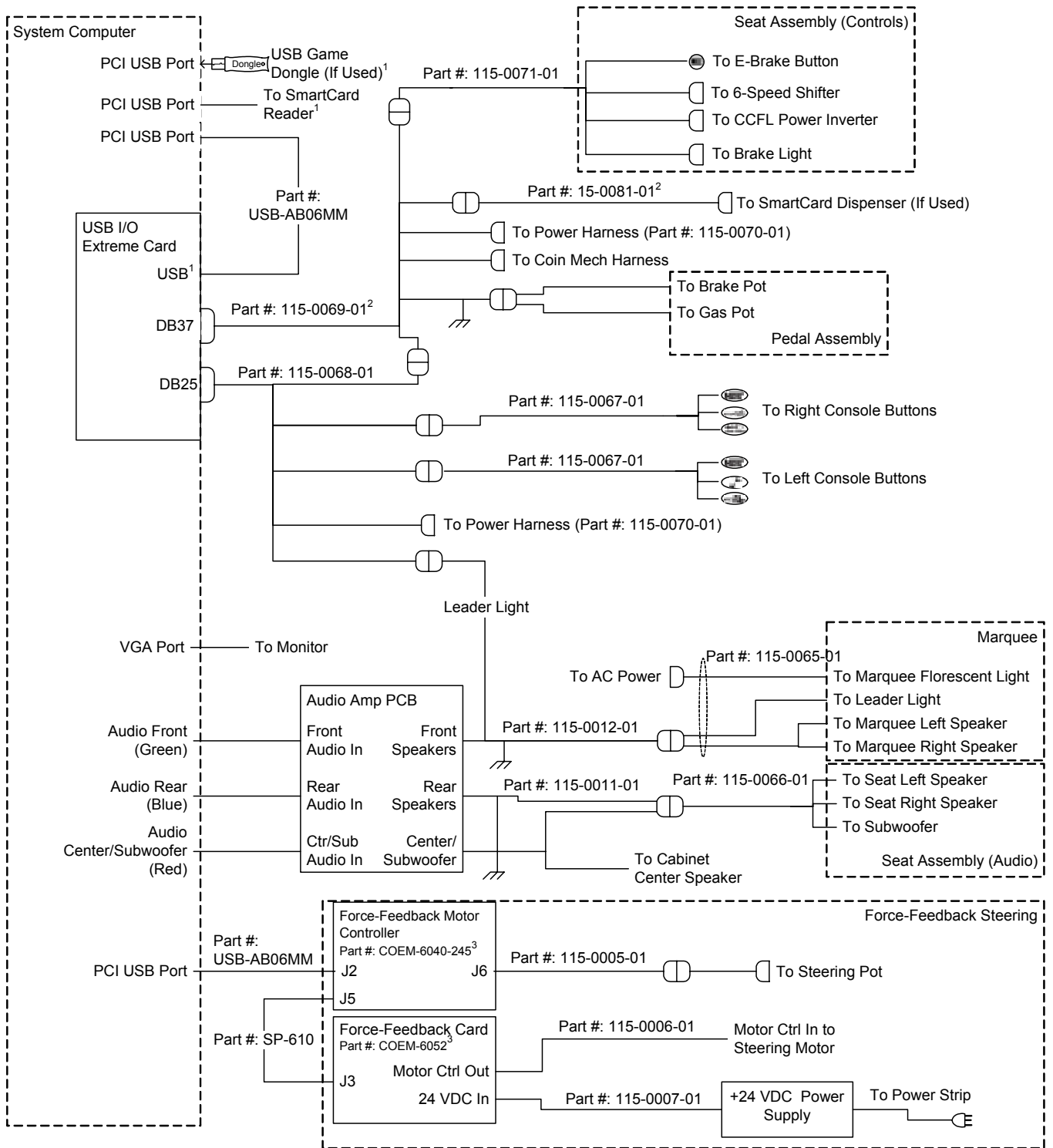

Figure 55. Audio Wiring



**Notes:**

<sup>1</sup>If a 2-port PCI USB card is installed, the SmartCard Reader, USB Port on USB I/O Extreme Board, and USB Game Dongle will connect through a USB Hub.

<sup>2</sup>Part numbers 115-0069-01 and 115-0081-01 can be replaced with 115-0084-01. (Do not use 115-0081-01 with 115-0084-01.)

<sup>3</sup>Part numbers COEM-6040-245 and COEM-6052 can be replaced with COEM-ELEC-AW-SB-GVR. (Single PCB replaces both.)

Figure 56. Simplified Wiring Diagram

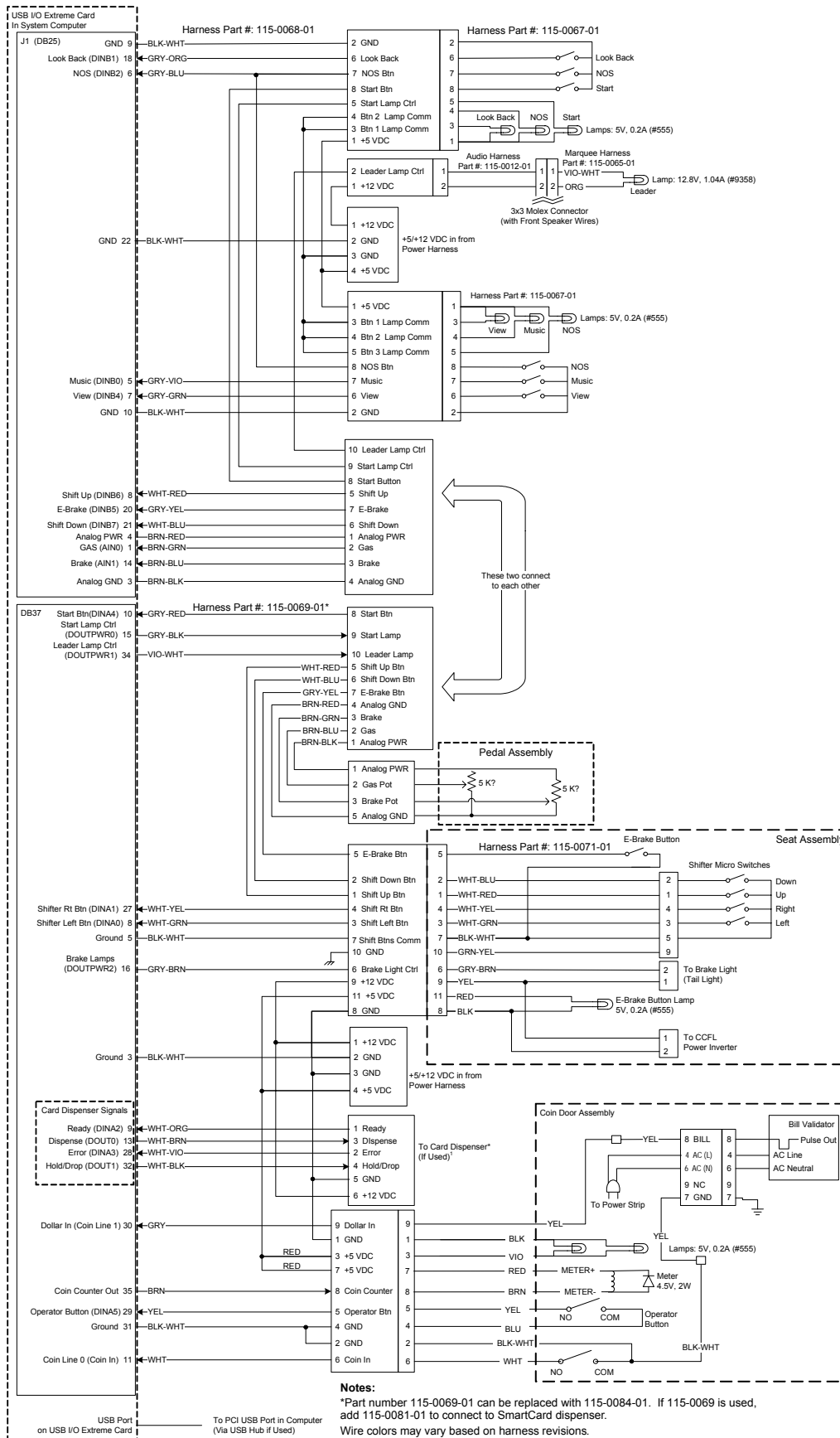

Figure 57. Detailed Wiring Diagram

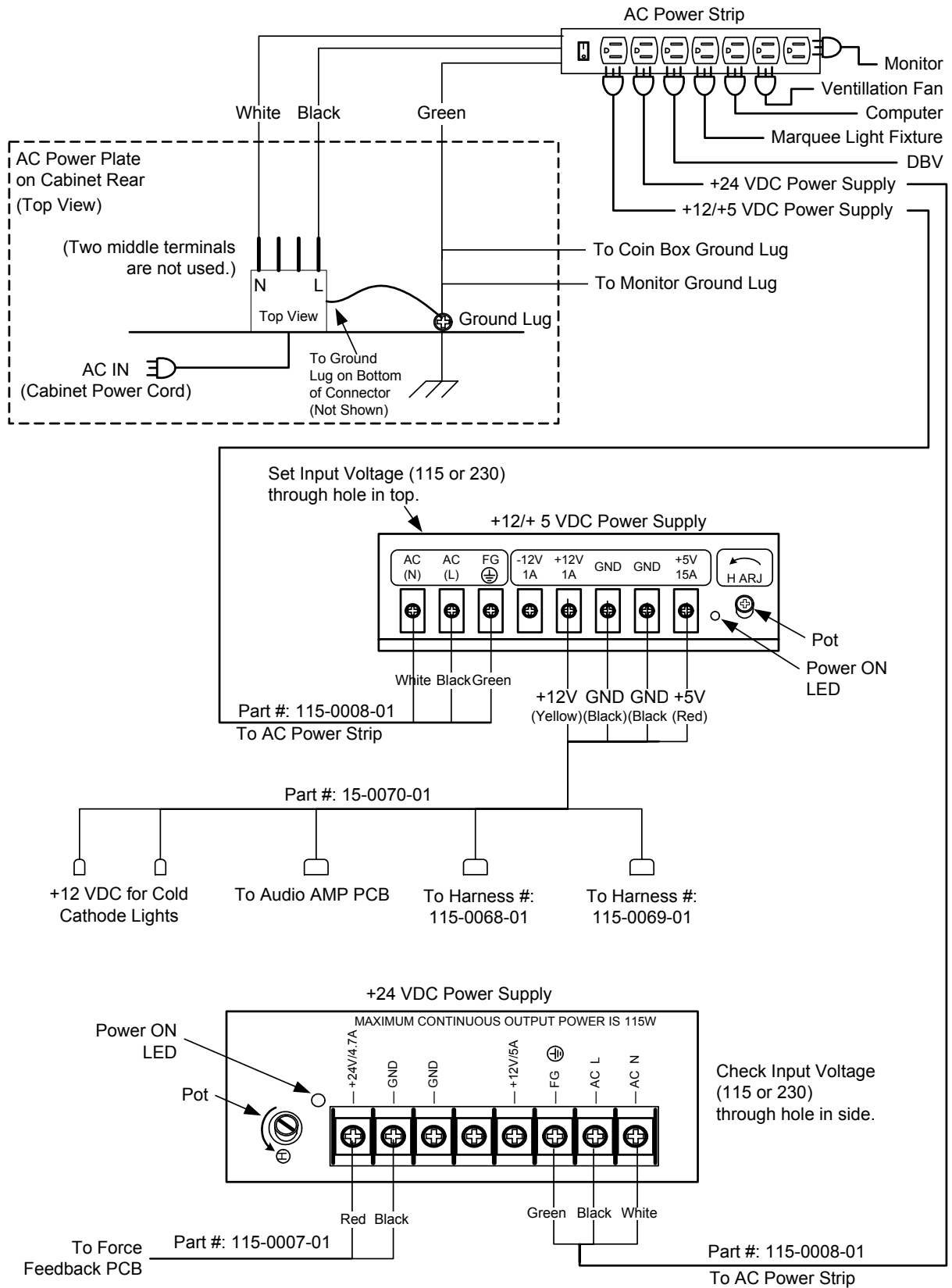

Figure 58. Power Distribution Diagram

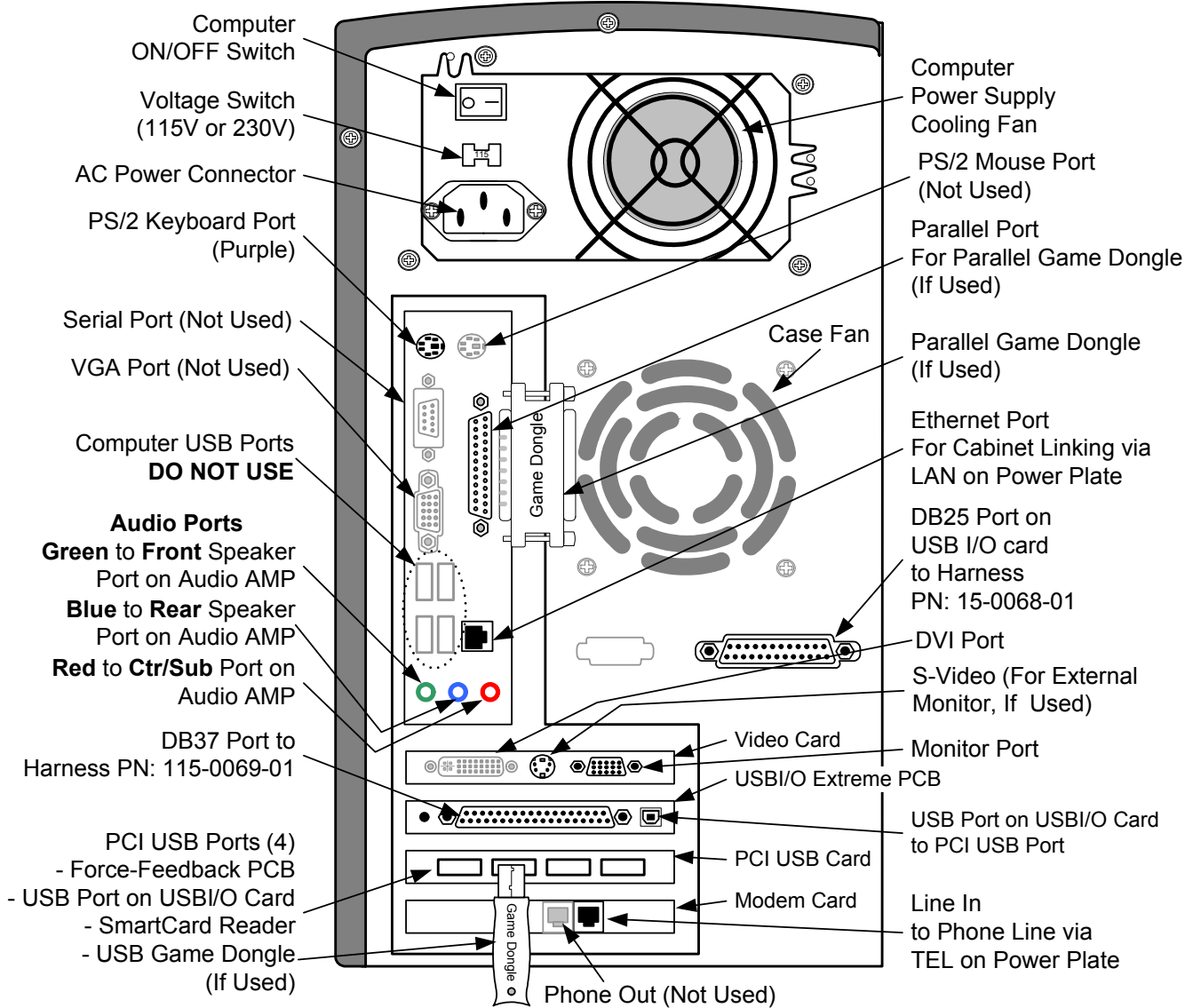

Figure 59. Computer Rear Panel Diagram

## Warranty Service

---

If at some point you require warranty service, contact your distributor. If the Technical Support staff determines that your game is defective, a Return Merchandise Authorization (RMA) number will be issued.

## Warranty Information

### LIMITED WARRANTY

GLOBAL VR® warrants that its computer circuit boards, hard drives, power supplies, monitors, displays, controls, sensors, and mechanical structures are free from defects in materials and workmanship under normal use and service for a period of ninety (90) days from the date of shipment.

All software and accompanying documentation furnished with, or as part of the Product, is supplied "AS IS" with no warranty of any kind except where expressly provided otherwise in any documentation or license agreement furnished with the Product.

During the warranty period, GLOBAL VR® will, at no charge, repair the Product, provided:

- Purchaser believes that the Product is defective in material or workmanship and promptly notifies GLOBAL VR® in writing with an explanation of the claim;
- All claims for warranty service are made within the warranty period;
- Products are returned adequately packed and freight prepaid to GLOBAL VR®'s designated service center;
- GLOBAL VR®'s inspection or test of the Product verifies to GLOBAL VR®'s satisfaction that the alleged defect(s) existed and were not caused by accident, misuse, neglect, unauthorized or attempted repair or testing, unauthorized modification, incorrect installation, vandalism, failure to follow the maintenance schedule or procedures; or operation in out-of-specification environmental conditions.

GLOBAL VR® will return the repaired Product freight prepaid to the Purchaser. All freight costs associated with replacement of warranty parts after expiration of the original warranty period are the responsibility of the Purchaser. GLOBAL VR® is not obligated to provide the Purchaser with a substitute unit or on-site service during the warranty period or at any time. If after investigation GLOBAL VR® determines that the reported problem was not covered by the warranty, Purchaser shall pay GLOBAL VR® for the cost of investigating the problem at its then prevailing per incident billing rate. No repair or replacement of any Product or part therein shall extend the warranty period as to the entire Product. The warranty on the repaired part only shall be in effect for a period of ninety (90) days following the repair or replacement of that part or the remaining period of the Product parts warranty, whichever is greater.

Purchaser's exclusive remedy and GLOBAL VR®'s sole obligation is to supply or pay for all labor necessary to repair any Product found to be defective within the warranty period and to supply, at no extra charge, new or rebuilt replacements for defective parts. If repair or replacement fails to remedy the defect, then, and only in such event, shall GLOBAL VR® refund to Purchaser the purchase price for said Product. Purchaser's failure to make a claim as provided above or continued use of the Product shall constitute an unqualified acceptance of said Product and a waiver by Purchaser of all claims thereto.

IN NO EVENT SHALL GLOBAL VR® BE LIABLE FOR LOSS OF PROFITS, LOSS OF USE, INCIDENTAL OR CONSEQUENTIAL DAMAGES RESULTING FROM OPERATION OF THE GAME IN ANY CONDITION. GLOBAL VR® SHALL NOT BE RESPONSIBLE FOR THE SUITABILITY, PERFORMANCE, OR SAFETY OF ANY NON- GLOBAL VR® PART OR ANY MODIFICATION PERFORMED BY ANY PRODUCT DISTRIBUTOR UNLESS SUCH WORK IS EXPRESSLY AUTHORIZED IN ADVANCE BY GLOBAL VR®.

THIS WARRANTY IS IN LIEU OF ALL OTHER EXPRESSED OR IMPLIED WARRANTIES, INCLUDING THE IMPLIED WARRANTIES OF MERCHANTABILITY AND FITNESS FOR A PARTICULAR PURPOSE, AND ALL OTHER OBLIGATIONS OR LIABILITIES ON GLOBAL VR®'S PART, EXCEPT FOR ANY EXPRESS WARRANTY SET FORTH IN A WRITTEN CONTRACT BETWEEN GLOBAL VR® AND PURCHASER CONTAINING SPECIFIC TERMS WHICH SUPERSEDE THE TERMS HEREIN. THIS WARRANTY DOES NOT AUTHORIZE ANY OTHER PERSON TO ASSUME OTHER LIABILITIES, IF ANY, CONNECTED WITH THE SALE OF PRODUCTS BY GLOBAL VR®.

## Technical Support

---

Free telephone, e-mail and online support are provided for systems during the warranty period. In addition to helping with troubleshooting and diagnosing defective parts, GLOBAL VR<sup>®</sup> Technical Support is prepared to help you with questions about the operation of your game.

When you contact Technical Support, please provide the following background information to aid our technical support process:

- Cabinet Serial Number (found on the back of the cabinet). Write your serial number below for easy reference.

**Cabinet Serial Number:** \_\_\_\_\_

- Your mailing address and telephone number.
- A summary of the question or a detailed description of the problem with your cabinet.

The additional information listed below, as applicable, may assist Technical Support in solving your problem quickly. The cabinet ID, software version, and last successful sync are shown on the Registration screen in the Operator Menu.

- |   |   |
|---|---|
| <ul style="list-style-type: none"><li>• <b>Specific error message</b></li><li>• <b>Software version number (From the Machine Information screen.)</b></li><li>• <b>Date of latest install or upgrade</b></li><li>• <b>Any changes made to the system</b></li><li>• <b>For game-play issues, the game mode and number of players</b></li></ul> | <b>For Online Cabinets:</b> <ul style="list-style-type: none"><li>• <b>Cabinet ID</b></li><li>• <b>Date of last successful sync (From the Registration Options screen.)</b></li></ul> |
|---|---|

Technical support is available from 6:00 AM to 6:00 PM, Pacific Time, Monday–Friday.

Call 408.597.3400 to reach a Technical Support staff member.

E-mail support is available at this address: [techsupport@globalvr.com](mailto:techsupport@globalvr.com)

Tournament E-mail Support is available at this address: [tournament@globalvr.com](mailto:tournament@globalvr.com)

To comment on this manual, please e-mail: [techpubs@globalvr.com](mailto:techpubs@globalvr.com)

Find technical documents and service bulletins online at: <http://service.globalvr.com>